

Repair Parts

C C O U N T R Y
CLIPPER
ZERO TURN MOWER

AVENUE

A125 / A125W

BOULEVARD

B225 / B225W

SERIAL RANGE: 24266001 - _____

COUNTRY CLIPPER
AVENUE-A125 / A125W & BOULEVARD-B225 / B225W
SERIAL RANGE 24266001 - _____
ZERO TURN RADIUS MOWER
TABLE OF CONTENTS

SECTION 1 – MOWER DECKS AND RELATED PARTS

1. 42" DECK ASSEMBLY
2. 48" DECK ASSEMBLY
3. 54" DECK ASSEMBLY
4. 60" DECK ASSEMBLY
5. DISCHARGE CHUTE ASSEMBLY
6. DECK SPINDLE ASSEMBLY
7. DOUBLE IDLER & RELATED PARTS (42", 48", 54" & 60" DECK)
8. BELT TENSION LEVER
9. FIXED IDLERS & RELATED PARTS
10. DECK LIFT ASSEMBLY & RELATED PARTS
11. DECK LIFT ASSEMBLY & RELATED PARTS (CONT)
12. CUT HEIGHT ASSEMBLY & RELATED PARTS

SECTION 2 – TRACTOR FRAME AND RELATED PARTS

13. FRONT & REAR TIRES (AVENUE)
14. FRONT & REAR TIRES (BOULEVARD)
15. FRONT PANEL ASSEMBLY & RELATED PARTS
16. FRONT PANEL ASSEMBLY & RELATED PARTS (CONT)
17. BATTERY & SOLENOID
18. PARKING BRAKE ASSEMBLY
19. PARKING BRAKE ASSEMBLY (AVENUE)
20. PARKING BRAKE ASSEMBLY (BOULEVARD)

SECTION 3 – TRACTOR DRIVE AND RELATED PARTS

21. DAMPER & OFFSET BRACKET
22. FUEL TANK ASSEMBLY
23. JOYSTICK CONTROL & RELATED PARTS
24. JOYSTICK ASSEMBLY
25. JOYSTICK ASSEMBLY MOUNTING & RELATED PARTS
26. TWIN LEVER CONTROL & RELATED PARTS
27. TWIN LEVER ASSEMBLY
28. CONTROL PANEL
29. FENDER ASSEMBLY & RELATED PARTS
30. TRANSMISSION ASSEMBLY & RELATED PARTS (AVENUE & BOULEVARD)
31. SEATS, ARM RESTS, & RELATED PARTS
32. ENGINES
33. ENGINE & CLUTCH MOUNTING & RELATED PARTS
34. WIRE HARNESS & RELATED PARTS
35. WIRE HARNESS SCHEMATIC

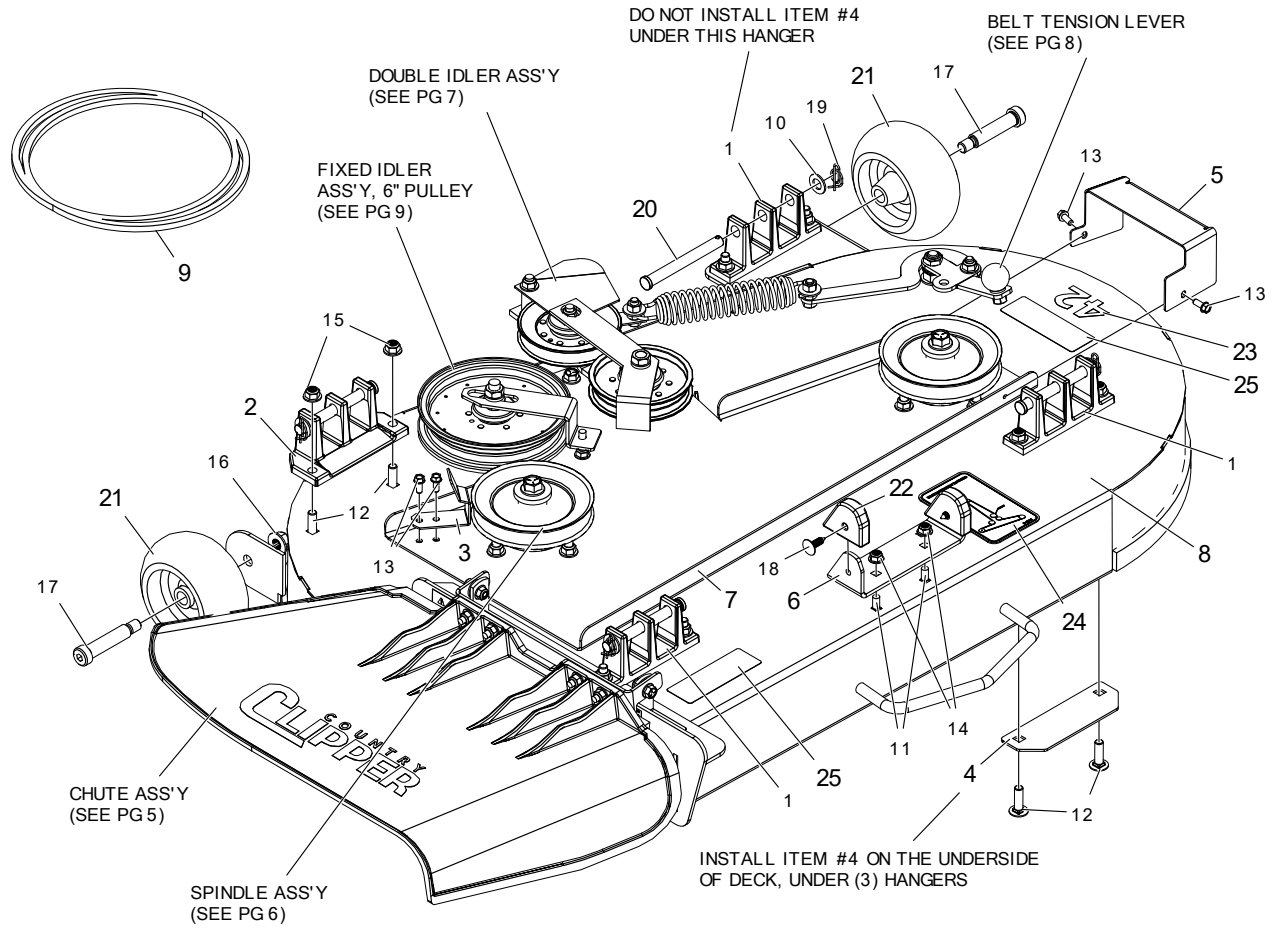

ITEM #	QTY	PART #	DESCRIPTION
1	3	643-016W	DECK HANGER, NARROW BASE
2	1	651-009W	DECK HANGER, WIDE BASE
3	1	700-058P	GUIDE, BELT
4	3	714-491P	REINFORCEMENT PLATE
5	1	714-497P	COVER, PULLEY 42
6	1	722-034P	DECK STOP
7	1	733A-005P	DECK STIFFENER, 42"
8	1	733-006A	42" DECK W/ DECALS
9	1	D-3948	BELT, BANDO, B-122
10	4	F-1521	WASHER, 1/2" CUSTOM, YZ
11	2	F-1671	CARRIAGE BOLT, 5/16-18 X 3/4", YZ, GR5
12	8	F-1672	BOLT, CARRIAGE, 3/8-16 X 1-1/4", YZ, GR5
13	4	F-2030	HEX, WASHER HEAD SCREW, 1/4 X 5/8", SELF-TAPPING, YZ
14	2	F-2063	NUT, 5/16-18, NYLOC, FLANGED, YZ
15	8	F-2151	NUT, 3/8-16 NYLOC, FLANGED, YZ
16	2	F-2152	NUT, 1/2-13 NYLOC, FLANGED, YZ
17	2	F-2232	SHCS, 5/8" X 2-1/2", YZ
18	2	F-2250	CLIP, FIR TREE, 1/4" X 1", BLACK NYLON
19	4	H-2239	1/2" RUE RING
20	4	H-2240	1/2" X 4-1/2" CLEVIS PIN
21	2	H-2968	ANTI-SCALP WHEEL, 5" X 2-1/2"
22	2	H-3091	WEAR PAD
23	1	P-11949	DECAL, DECK SIZE, 42
24	1	P-12712	DECAL WRANGLER BELT ROUTING
25	2	P-13749	DECAL, DECK SAFETY

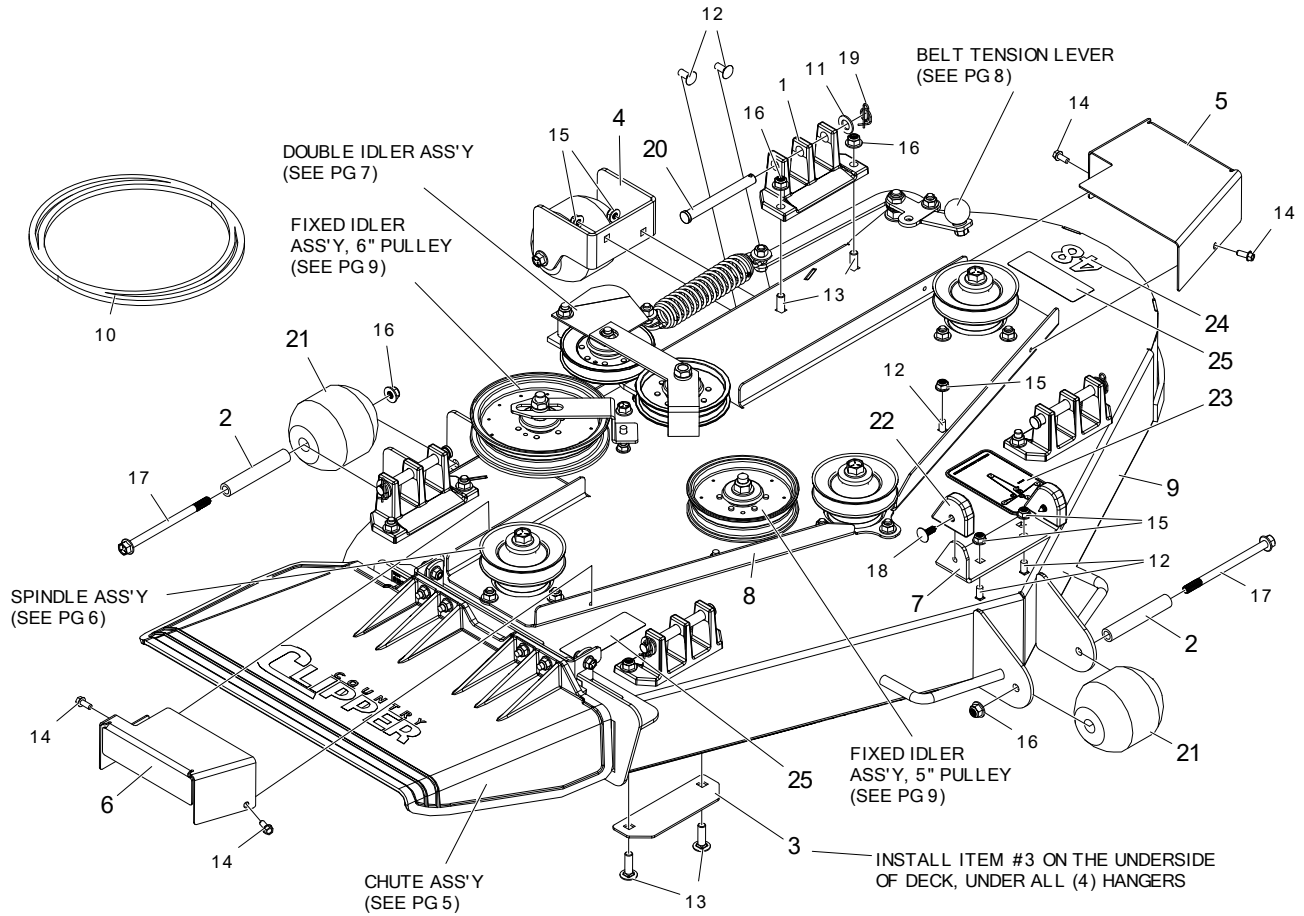

ITEM #	QTY	PART #	DESCRIPTION
1	4	651-009W	DECK HANGER, WIDE BASE
2	3	714-133P	BUSHING, ROLLER BRACKET
3	4	714-491P	REINFORCEMENT PLATE
4	2	714-492P	BRKT, REAR WHEEL
5	1	714-583P	COVER, PULLEY, 2L
6	1	714-584P	COVER, PULLEY, 2R
7	1	722-034P	DECK STOP
8	1	733B-005P	STIFFENER, DECK 48
9	1	733-007A	48" DECK W/ DECALS
10	1	D-3949	BANDL BELT B-144
11	4	F-1521	WASHER, 1/2" CUSTOM, YZ
12	8	F-1671	CARRIAGE BOLT, 5/16-18 X 3/4", YZ, GR5
13	8	F-1672	BOLT, CARRIAGE, 3/8-16 X 1-1/4", YZ, GR5
14	4	F-2030	HEX, WASHER HEAD SCREW, 1/4 X 5/8", SELF-TAPPING, YZ
15	8	F-2063	NUT, 5/16-18, NYLOC, FLANGED, YZ
16	11	F-2151	NUT, 3/8-16 NYLOC, FLANGED, YZ
17	3	F-2222	FHCS, 3/8-16 X 5-1/2", YZ, GR5
18	2	F-2250	CLIP, FIR TREE, 1/4" X 1", BLACK NYLON
19	4	H-2239	1/2" RUE RING
20	4	H-2240	1/2" X 4-1/2" CLEVIS PIN
21	3	H-2768	ROLLER, 3-3/4 DIA. X 4"
22	2	H-3091	WEAR PAD
23	1	P-11932	DECK BELT ROUTING
24	1	P-11950	DECAL, DECK SIZE, 48
25	2	P-13749	DECAL, DECK SAFETY

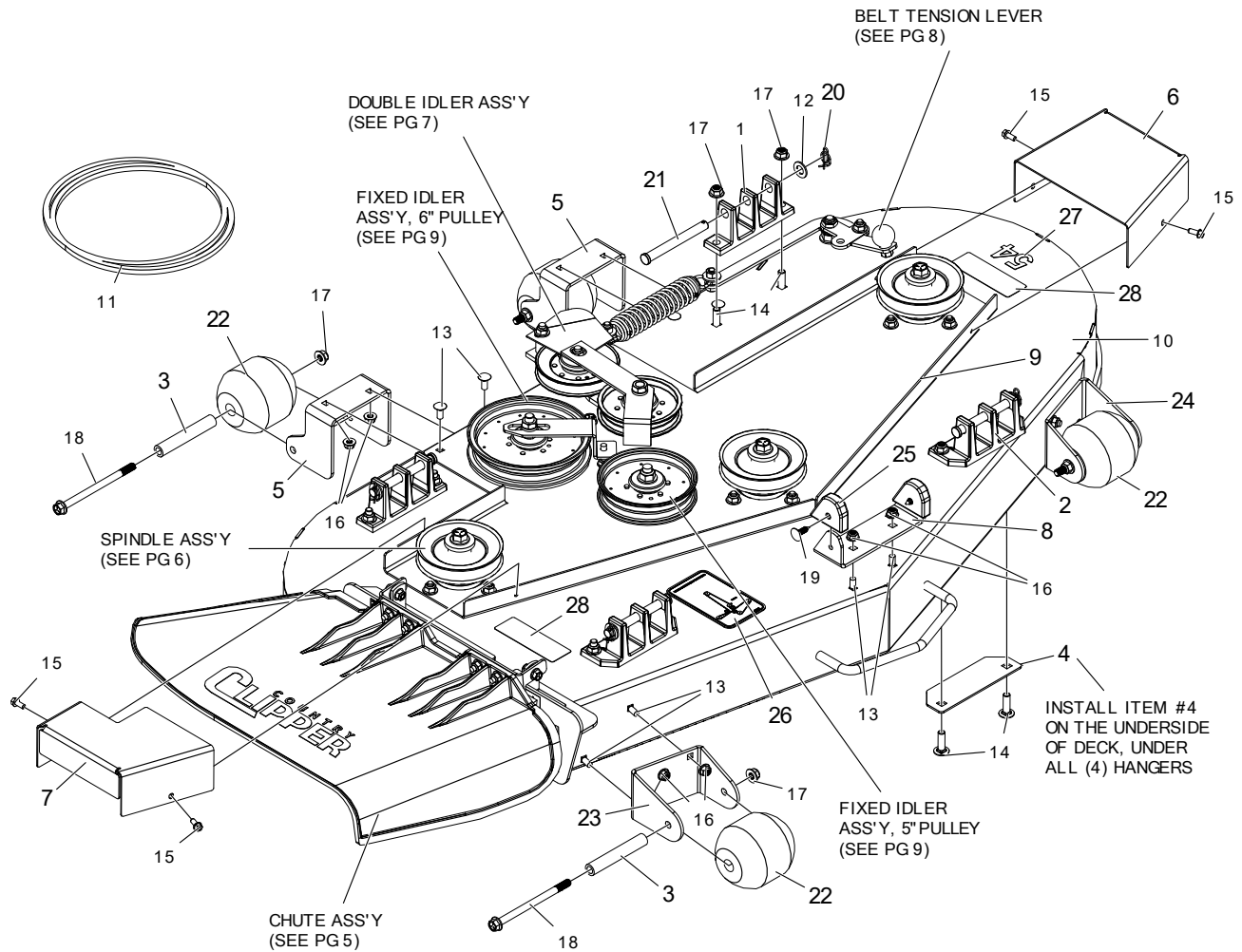

ITEM #	QTY	PART #	DESCRIPTION
1	2	643-016W	DECK HANGER, NARROW BASE
2	2	651-009W	DECK HANGER, WIDE BASE
3	4	714-133P	BUSHING, ROLLER BRACKET
4	4	714-491P	REINFORCEMENT PLATE
5	2	714-492P	BRKT, REAR WHEEL
6	1	714-585P	COVER, PULLEY, 3L
7	1	714-586P	COVER, PULLEY, 3R
8	1	722-034P	DECK STOP
9	1	733C-005P	STIFFENER, DECK 54
10	1	733-008A	54" DECK W/ DECALS
11	1	D-3950	BANDL BELT B-154
12	4	F-1521	WASHER, 1/2" CUSTOM, YZ
13	10	F-1671	CARRIAGE BOLT, 5/16-18 X 3/4", YZ, GR5
14	8	F-1672	BOLT, CARRIAGE, 3/8-16 X 1-1/4", YZ, GR5
15	4	F-2030	HEX, WASHER HEAD SCREW, 1/4 X 5/8", SELF-TAPPING, YZ
16	10	F-2063	NUT, 5/16-18, NYLOC, FLANGED, YZ
17	12	F-2151	NUT, 3/8-16 NYLOC, FLANGED, YZ
18	4	F-2222	FHCS, 3/8-16 X 5-1/2", YZ, GR5
19	2	F-2250	CLIP, FIR TREE, 1/4" X 1", BLACK NYLON
20	4	H-2239	1/2" RUE RING
21	4	H-2240	1/2" X 4-1/2" CLEVIS PIN
22	4	H-2768	ROLLER, 3-3/4 DIA. X 4"
23	1	H-2938	PLATE, ROLLER BRACKET
24	1	H-2939	PLATE, ROLLER BRACKET
25	2	H-3091	WEAR PAD
26	1	P-11932	DECK BELT ROUTING
27	1	P-13131	DECAL, 54
28	2	P-13749	DECAL, DECK SAFETY

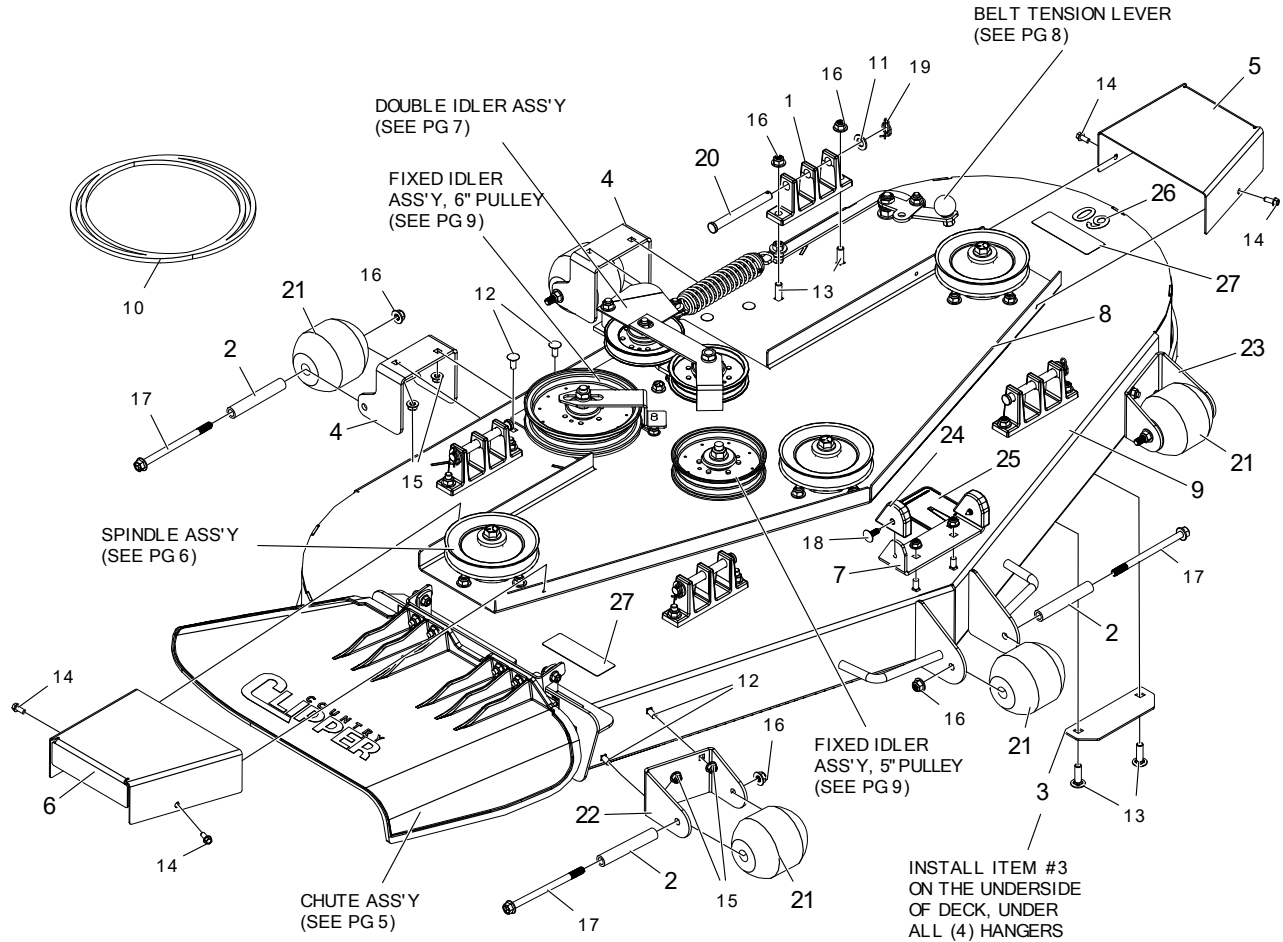

ITEM #	QTY	PART #	DESCRIPTION
1	4	643-016W	DECK HANGER, NARROW BASE
2	5	714-133P	BUSHING, ROLLER BRACKET
3	4	714-491P	REINFORCEMENT PLATE
4	2	714-492P	BRKT, REAR WHEEL
5	1	714-585P	COVER, PULLEY, 3L
6	1	714-587P	COVER, PULLEY, 4R
7	1	722-034P	DECK STOP
8	1	733D-005P	STIFFENER, DECK 60"
9	1	733-009A	60" DECK W/ DECALS
10	1	D-3951	BANDL BELT B-166
11	4	F-1521	WASHER, 1/2" CUSTOM, YZ
12	10	F-1671	CARRIAGE BOLT, 5/16-18 X 3/4", YZ, GR5
13	8	F-1672	BOLT, CARRIAGE, 3/8-16 X 1-1/4", YZ, GR5
14	4	F-2030	HEX, WASHER HEAD SCREW, 1/4 X 5/8", SELF-TAPPING, YZ
15	10	F-2063	NUT, 5/16-18, NYLOC, FLANGED, YZ
16	13	F-2151	NUT, 3/8-16 NYLOC, FLANGED, YZ
17	5	F-2222	FHCS, 3/8-16 X 5-1/2", YZ, GR5
18	2	F-2250	CLIP, FIR TREE, 1/4" X 1", BLACK NYLON
19	4	H-2239	1/2" RUE RING
20	4	H-2240	1/2" X 4-1/2" CLEVIS PIN
21	5	H-2768	ROLLER, 3-3/4 DIA. X 4"
22	1	H-2938	PLATE, ROLLER BRACKET
23	1	H-2939	PLATE, ROLLER BRACKET
24	2	H-3091	WEAR PAD
25	1	P-11932	DECK BELT ROUTING
26	1	P-11952	DECAL, DECK SIZE, 60
27	2	P-13749	DECAL, DECK SAFETY

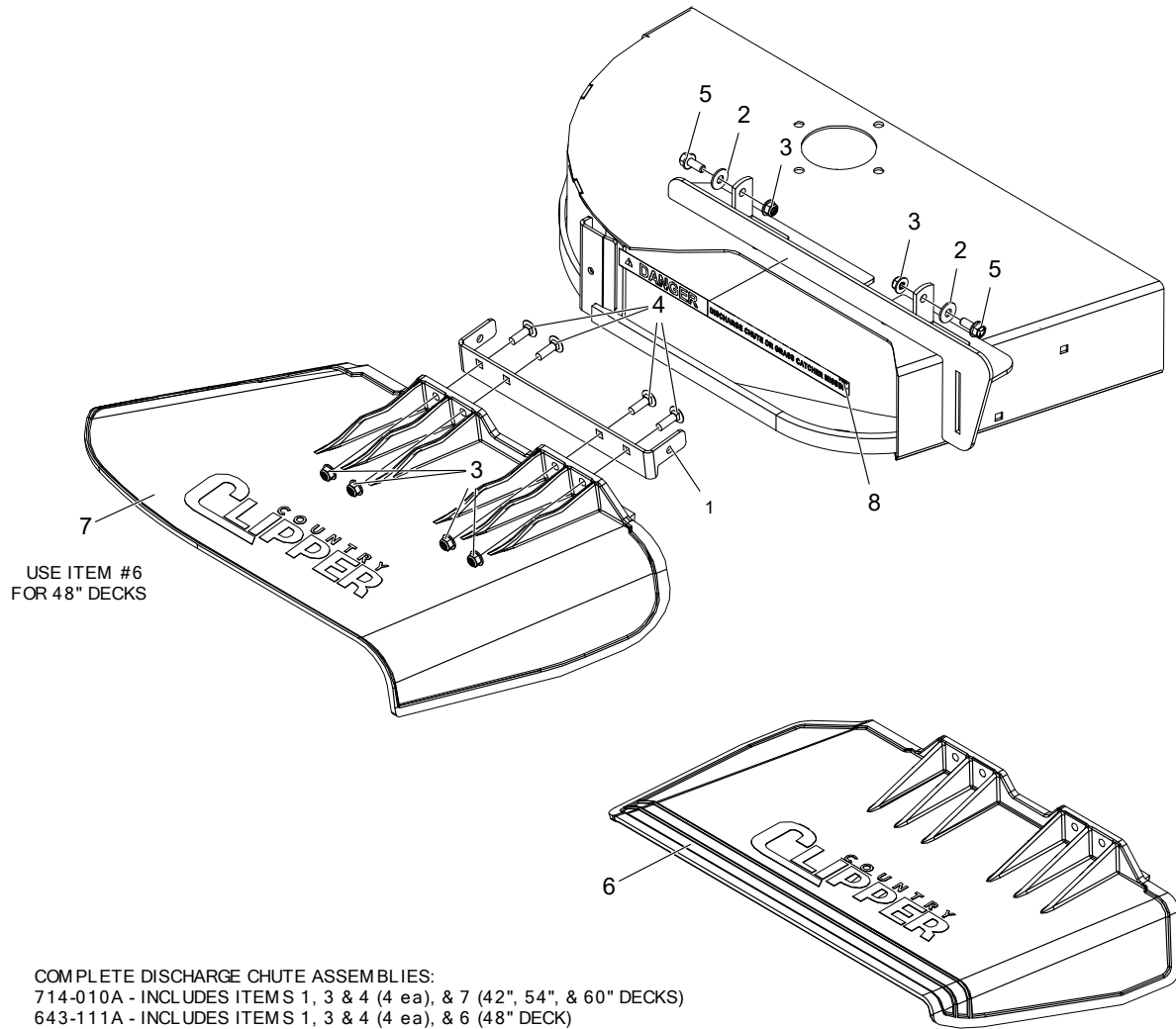

COMPLETE DISCHARGE CHUTE ASSEMBLIES:
 714-010A - INCLUDES ITEMS 1, 3 & 4 (4 ea), & 7 (42", 54", & 60" DECKS)
 643-111A - INCLUDES ITEMS 1, 3 & 4 (4 ea), & 6 (48" DECK)

ITEM #	QTY	PART #	DESCRIPTION
1	1	714-112P	HINGE, DECK CHUTE
2	2	F-1009-02	WASHER, FLAT
3	6	F-2063	NUT, 5/16-18, NYLOC, FLANGED, YZ
4	4	F-2066	BOLT, CARRIAGE, 5/16-18 X 1", YZ, GR5
5	2	F-2120	FHCS, 5/16-18 X 3/4", YZ, GR5
6	1	H-2723	CHUTE, DISCHARGE, SMALL
7	1	H-2946	DECK CHUTE
8	1	P-13266	DECAL, MISSING CHUTE

BLADE PARTNUMBERS

42" & 60" DECK

- H-2885 HIGH LIFT W/O FUSION (STANDARD)
- H-2886 HIGH LIFT W/ FUSION
- H-2661 LOW LIFT
- H-2667 GATOR

48" DECK

- H-2882 HIGH LIFT W/O FUSION (STANDARD)
- H-2659 LOW LIFT
- H-2665 GATOR

54" DECK

- H-2883 HIGH LIFT W/O FUSION (STANDARD)
- H-2884 HIGH LIFT W/ FUSION
- H-2660 LOW LIFT
- H-2666 GATOR

PARTS MARKED "*" ARE PART
OF COMPLETE ASS'Y D-4198

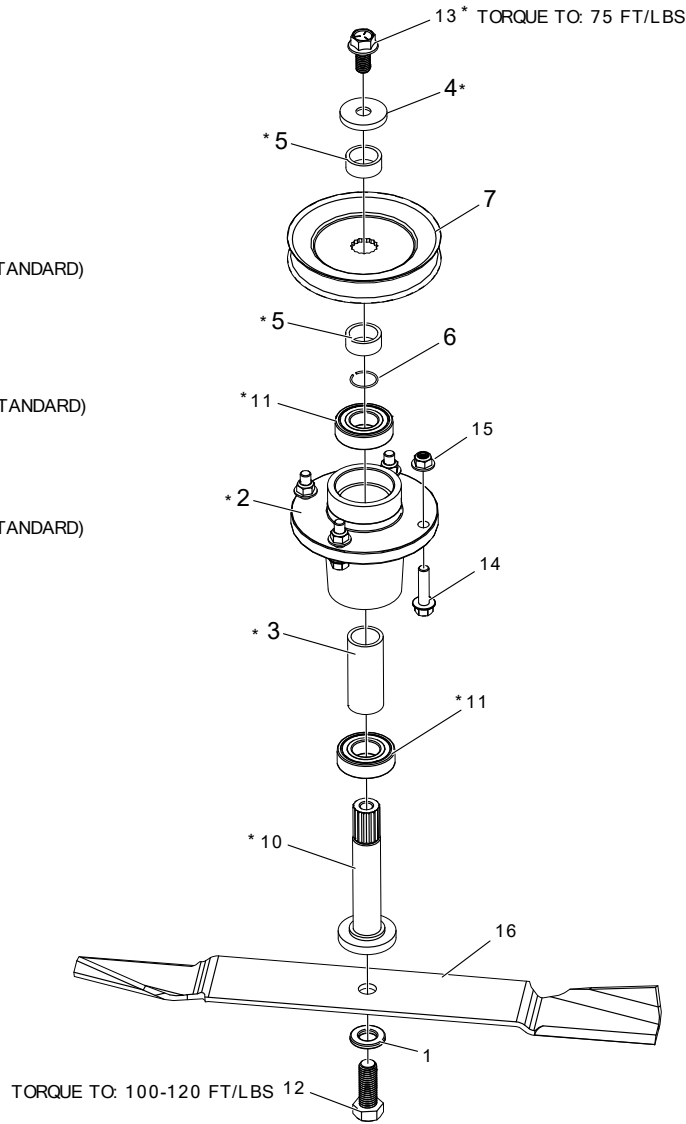

TORQUE TO: 100-120 FT/LBS 12

ITEM #	QTY	PART #	DESCRIPTION
1	1	660-099P	WASHER, BLADE, 5/8
2	1	----	SPINDLE HOUSING
3	1	----	SPINDLE SPACER
4	1	D-3990	SPINDLE HARD WASHER
5	2	D-4197	SPINDLE OUTER SPACER
6	1	D-3991	SPINDLE RETAINING RING
7	1	D-3918	PULLEY, 5.195, A-B, 42" & 60" DECK
-	1	D-3919	PULLEY, 4.039, A-B, 48" DECK
-	1	D-3920	PULLEY, 4.513, A-B, 54" DECK
10	1	D-3961	SPINDLE SHAFT
11	2	D-3058	SPINDLE BRG
12	1	F-2344	HHCS, 5/8-11 X 1-3/4", GR5
13	1	F-2143	FHCS, 1/2-13 X 1", YZ, GR5

ITEM #	QTY	PART #	DESCRIPTION
14	4	F-2147	FHCS, 3/8-16 X 1-1/2", YZ, GR5
15	4	F-2151	NUT, 3/8-16 NYLOC, FLANGED, YZ
16	1	H-2882	BLADE, HL, 16.928, 48 (STANDARD)
-	1	H-2883	BLADE, HL, 18.375, 54 (STANDARD)
-	1	H-2885	BLADE, HL, 20.953, 42 & 60 (STANDARD)
-	1	H-2884	BLADE, HL FUSION, 18.375, 54
-	1	H-2886	BLADE, HL FUSION, 20.953, 42 & 60
-	1	H-2659	BLADE, 16.928 X .63, LOW LIFT, 48
-	1	H-2660	BLADE, 18.375 X .63, LOW LIFT, 54
-	1	H-2661	BLADE, 20.953 X .63, LOW LIFT, 42 & 60
-	1	H-2665	BLADE, 16.928 X .63, GATOR, 48
-	1	H-2666	BLADE, 18.375 X .63, GATOR, 54
-	1	H-2667	BLADE, 20.86 X .63, GATOR, 42 & 60

DOUBLE IDLER DRIVE BELT IDLER
42", 48", 54", & 60" DECKS

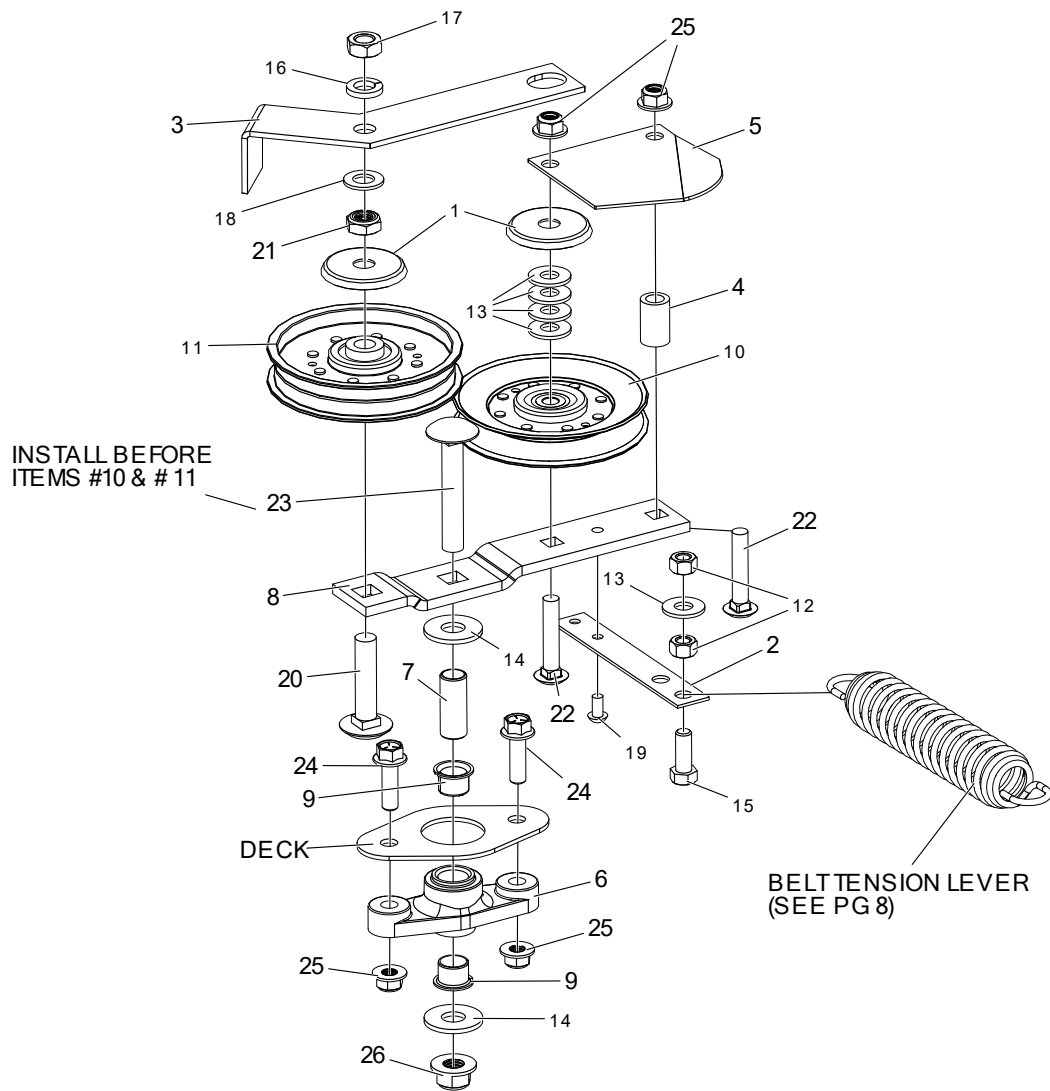

ITEM #	Qty	PART #	DESCRIPTION
1	2	620-201P	WASHER, BEARING CAP
2	1	660-081P	EXTENSION, SPRING
3	1	660-110P	BELT KEEPER, B BELT
4	1	668-021P	SPACER, BELT GUARD
5	1	714-183P	BELT GUARD, 54"
6	1	714-488P	MOUNT, DOUBLE IDLER
7	1	722-031P	MOUNTING PIN
8	1	722-032P	IDLER ARM
9	2	D-3730	BUSHING, DU 5/8 DIA X 1/2 LG
10	1	D-3923	PULLEY, V-IDLER, 4.59 OD,
11	1	D-3924	PULLEY, FLAT IDLER, 4.25 OD
12	2	F-1005-03	NUT, 3/8-16, CENTER LK, YZ, GR5
13	5	F-1009-03	WASHER, FLAT, 3/8, YZ

ITEM #	Qty	PART #	DESCRIPTION
14	2	F-1009-05	WASHER, FLAT STD, 1/2" NOMINAL, YZ
15	1	F-1394	HHCS, 3/8-16NC X 1", GR.5, YZ
16	1	F-1464	LOCK WASHER, 1/2"
17	1	F-1489	NUT, HEX, JAM, 1/2-13, YZ
18	1	F-1521	WASHER, 1/2" CUSTOM, YZ
19	1	F-1733	DRIVE SCREW, 1/4" X 1/2", RND HD
20	1	F-1822	BOLT, CARRIAGE, 1/2-13 X 2-1/4", YZ, GR5
21	1	F-1966	NUT, THIN, 1/2-13, NYLOC, YZ
22	2	F-1976	BOLT, CARRIAGE, 3/8-16 X 2", YZ, GR5
23	1	F-2047	CARRIAGE BOLT, 1/2-13 X 3" YZ, FULL THD
24	2	F-2125	FHCS, 3/8-16 X 1-1/4", YZ, GR5
25	4	F-2151	NUT, 3/8-16 NYLOC, FLANGED, YZ
26	1	F-2152	NUT, 1/2-13 NYLOC, FLANGED, YZ

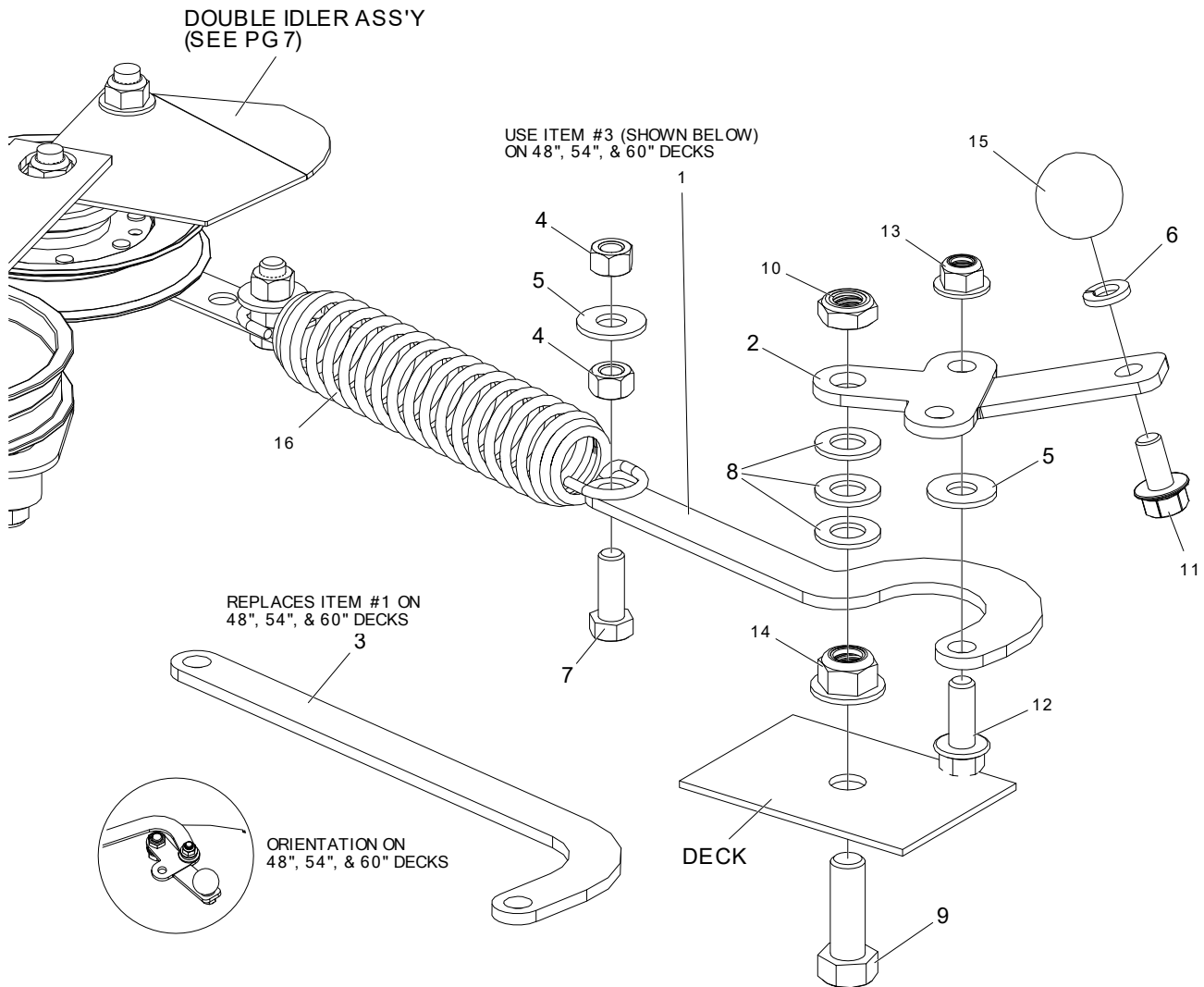

ITEM #	QTY	PART #	DESCRIPTION
1	1	660-031P	BELT TIGHTENER ARM
2	1	660-184P	HANDLE, BELT TENSIONER
3	1	714-180P	BELT TENSION ARM
4	2	F-1005-03	NUT, 3/8-16, CENTERLOCK, YZ, GR5
5	2	F-1009-03	WASHER, FLAT, 3/8, YZ
6	1	F-1019-03	LOCKWASHER, HVY, 3/8, YZ
7	1	F-1394	HHCS, 3/8-16NC X 1", GR.5, YELLOW PLATED
8	3	F-1521	WASHER, 1/2" CUSTOM, YZ
9	1	F-1526	HHSCREW, 1/2-13 UNC X 1-1/2 GR. 5 YELLOW PLATED
10	1	F-1966	NUT, THIN, 1/2-13, NYLOC, YZ
11	1	F-2124	FHCS, 3/8-16 X 3/4", YZ, GR5
12	1	F-2141	FHCS, 3/8-16 X 1", YZ, GR5
13	1	F-2151	NUT, 3/8-16 NYLOC, FLANGED, YZ
14	1	F-2152	NUT, 1/2-13 NYLOC, FLANGED, YZ
15	1	H-2405	BALL, 1-1/4"
16	1	H-2619	SPRING, 5 X 1-1/2, TAPERED ENDS

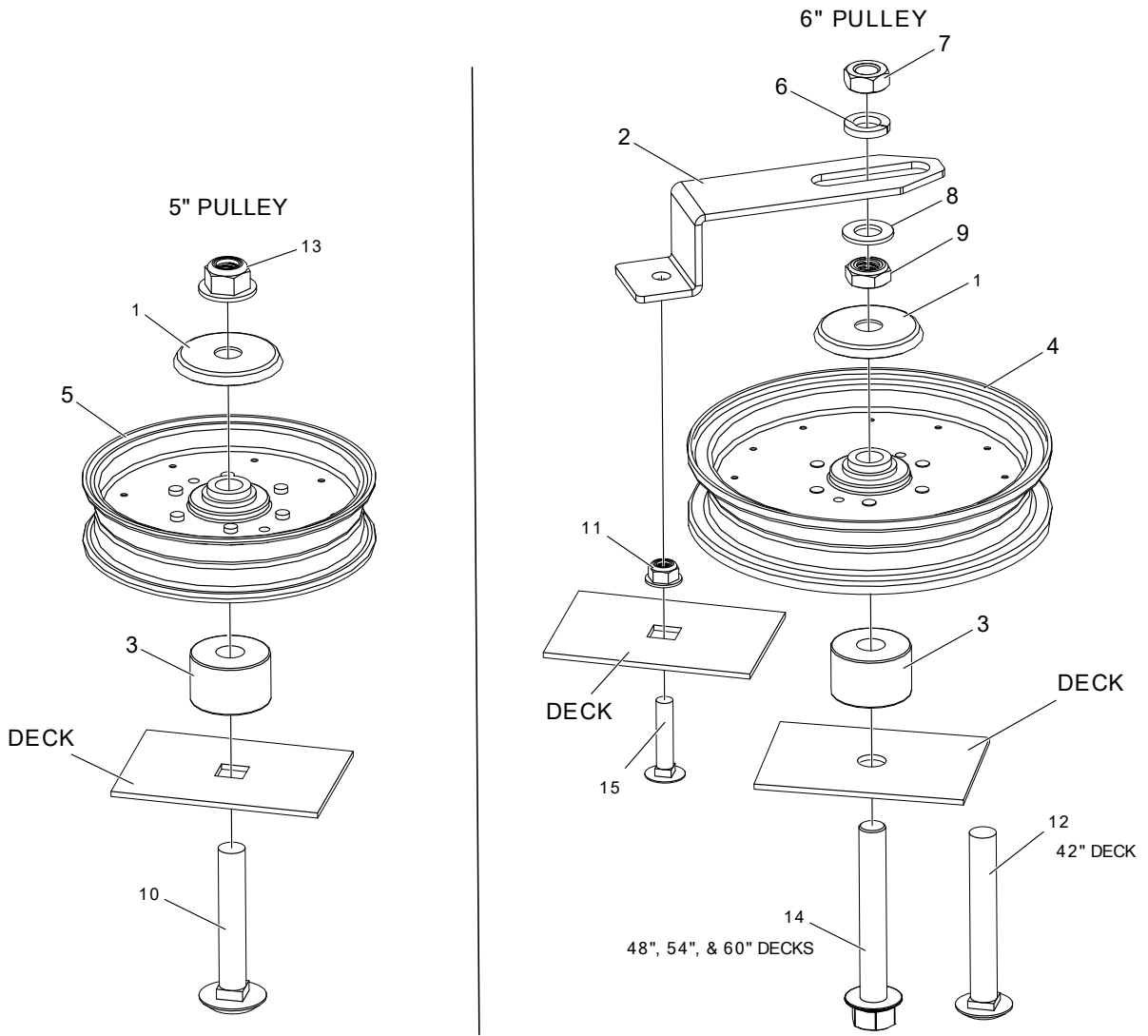

ITEM #	QTY	PART #	DESCRIPTION
1	2	620-201P	WASHER, BEARING CAP
2	1	660-114P	BELT KEEPER, SINGLE END
3	2	714-487P	SPACER, PULLEY
4	1	D-3903	PULLEY, FLAT IDLER, 6"
5	1	D-3904	PULLEY, FLAT IDLER, 5"
6	1	F-1464	LOCK WASHER, 1/2"
7	1	F-1489	NUT, HEX, JAM, 1/2-13, YZ
8	1	F-1521	WASHER, 1/2" CUSTOM, YZ
9	1	F-1966	NUT, THIN, 1/2-13, NYLOC, YZ
10	1	F-2047	CARRIAGE BOLT, 1/2-13 X 3" YZ, FULL THD
11	1	F-2063	NUT, 5/16-18, NYLOC, FLANGED, YZ
12	1	F-2106	BOLT, CARRIAGE, 1/2-13 X 3-1/2", YZ, GR5
13	1	F-2152	NUT, 1/2-13 NYLOC, FLANGED, YZ
14	1	F-2163	FHCS, 1/2-13 X 3-1/2", YZ, GR5
15	1	F-2264	CARRIAGE BOLT, 5/16-18 X 1-1/2", CZ, GR5

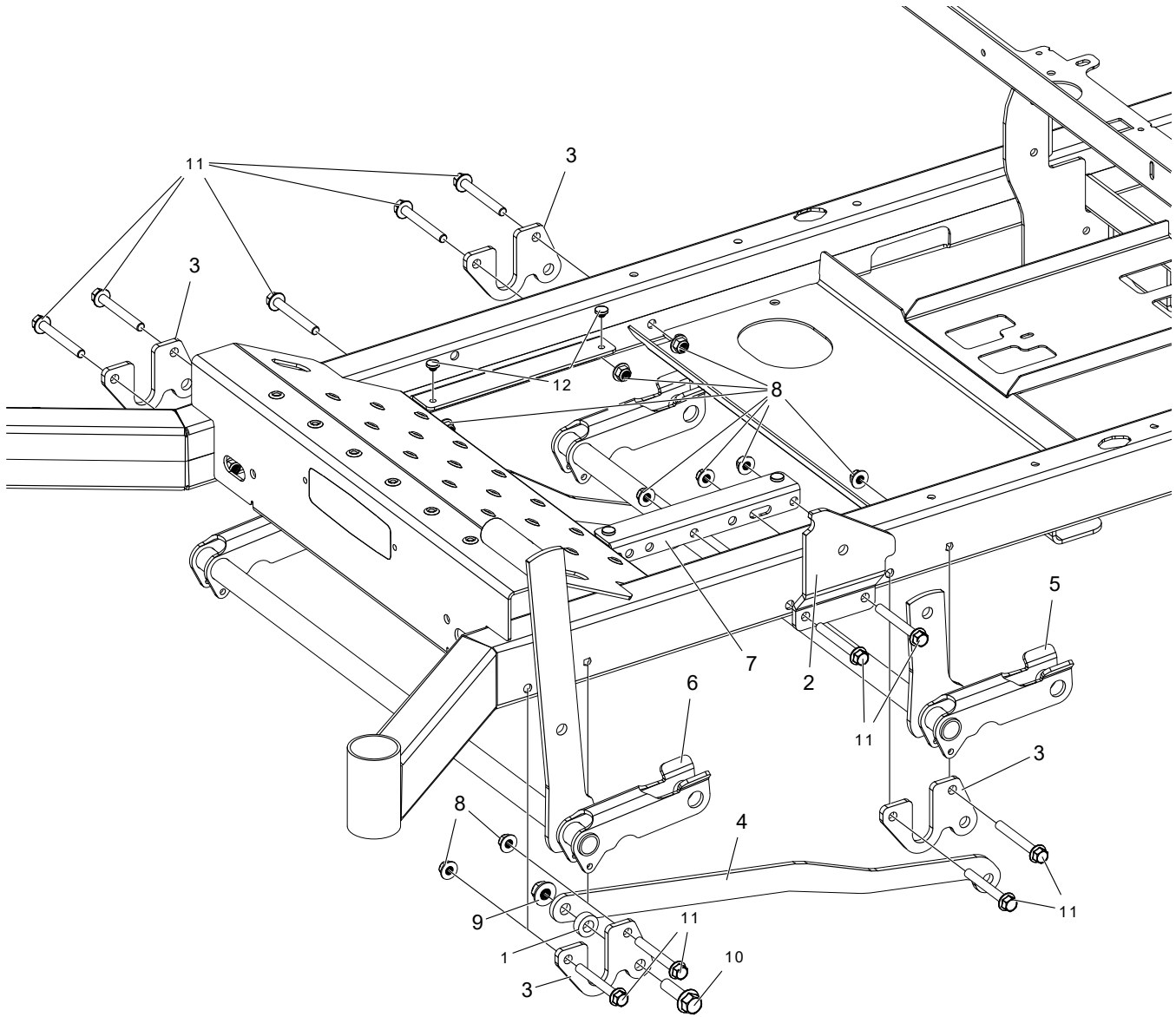

ITEM #	QTY	PART #	DESCRIPTION
1	2	660-038P	SPACER, 3/8" WIDE
2	1	714-472P	PLATE, DECK STOP
3	4	714-474P	DECK HANGER
4	2	714-500P	DRAG BAR
5	4	714-518W	WLDT, REAR DECK LIFT
6	4	714-519W	WLDT, FRONT DECK LIFT
7	2	720-094P	FLOOR PAN SUPPORT
8	11	F-2151	NUT, 3/8-16 NYLOC, FLANGED, YZ
9	2	F-2152	NUT, 1/2-13 NYLOC, FLANGED, YZ
10	2	F-2154	FHCS, 1/2-13 x 1-3/4", YZ, GR5
11	11	F-2180	FHCS, 3/8-16 x 3", YZ, GR5
12	4	H-2461	RUBBER BUMPER

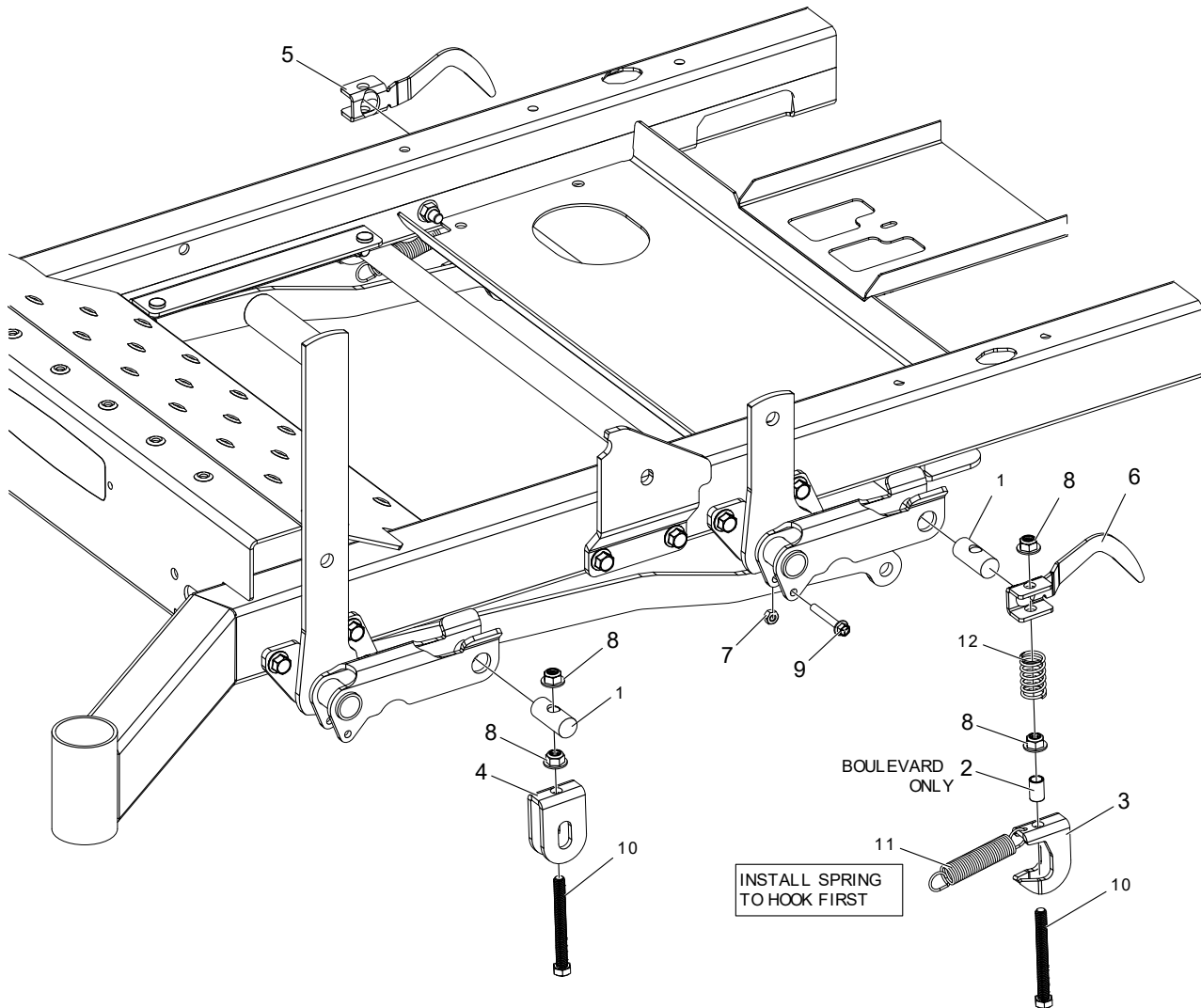

ITEM #	QTY	PART #	DESCRIPTION
1	4	642-067P	TOP HANGER PIN
2	2	707-073P	STAND-OFF, LINKAGE MOUNT (BOULEVARD)
3	2	714-504P	REAR DECK HANGER
4	2	714-505P	FRONT DECK HANGER
5	1	714-506P	DISCONNECT ARM, RH
6	1	714-507P	DISCONNECT ARM, LH
7	2	F-1158	CENTER LOCKING NUT, 1/4-20, GR5, YZ
8	8	F-2151	NUT, 3/8-16 NYLOC, FLANGED, YZ
9	2	F-2216	FHCS, 1/4-20 X 1-3/4, YZ, GR5
10	4	F-2349	HHCS, 3/8-16 X 3-1/2", GR5, ZN, FULL THREAD
11	2	H-1635	SPRING, EXT, 3/4" OD X 4" OAL
12	2	H-3270	COMPRESSION SPRING, DECK HOOK

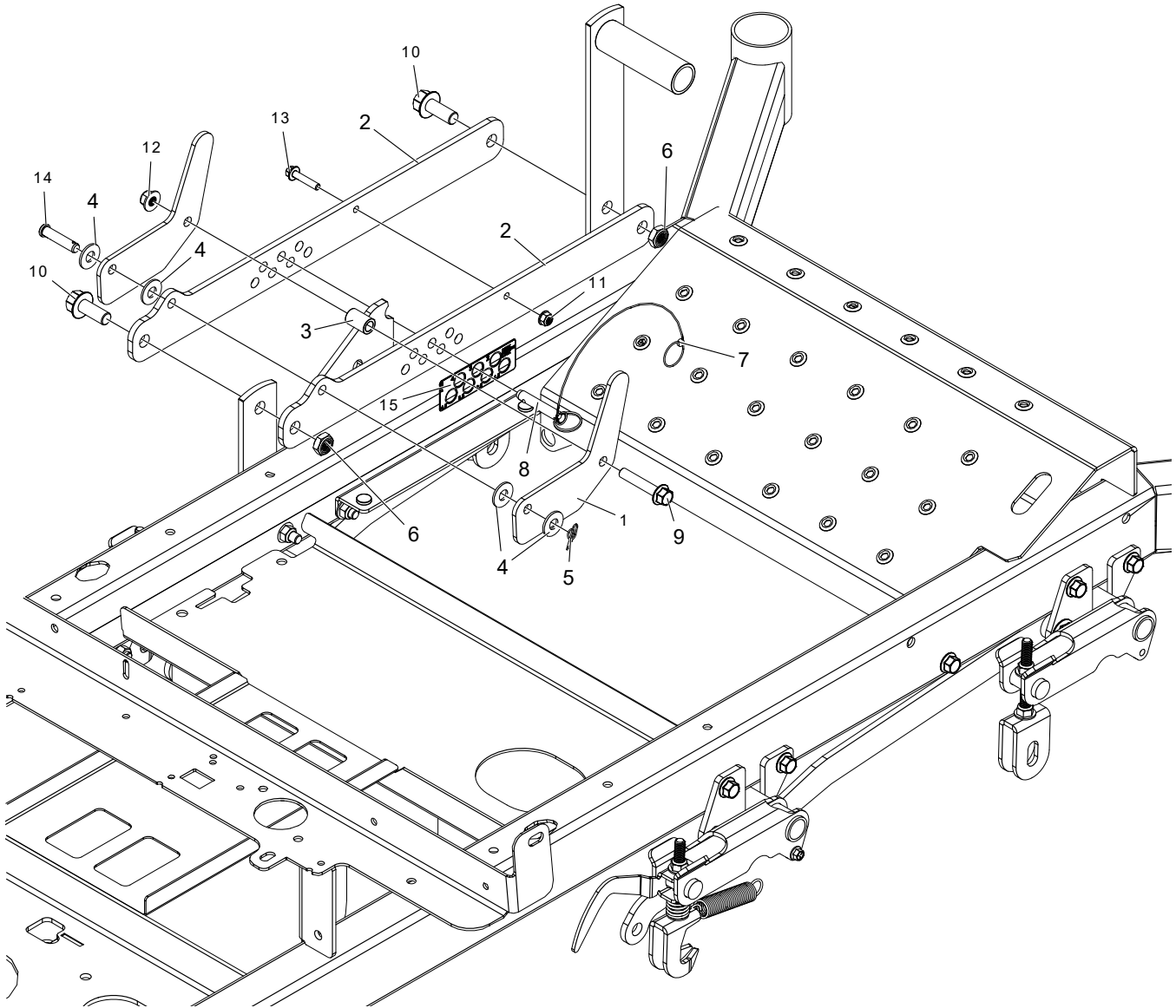

ITEM #	QTY	PART #	DESCRIPTION
1	2	714-502P	TOP CATCH LEVER
2	2	714-508P	DECK CUT HEIGHT BAR
3	1	724-079P	SPACER, CATCH PLATE
4	4	F-1009-03	WASHER, FLAT, 3/8, YZ
5	1	F-1492	RUE RING, 5/16
6	2	F-1966	NUT, THIN, 1/2-13, NYLOC, YZ
7	1	F-2069	PLASTIC LANYARD
8	1	F-2096	LOCK PIN, POSITIVE 3/8 X 1-1/2"
9	1	F-2126	FHCS, 3/8-16 X 2", YZ, GR5
10	2	F-2127	FHCS, 1/2-13 X 1-1/4", YZ, GR5
11	1	F-2132	NUT, 1/4-20 NYLOC, FLANGED, YZ
12	1	F-2151	NUT, 3/8-16 NYLOC, FLANGED, YZ
13	1	F-2182	FHCS, 1/4-20 X 1-1/4", YZ, GR5
14	1	F-2350	CLEVIS PIN, 3/8" X 1-5/8" X 1-3/8" USABLE, ZN
15	1	P-13684	DECAL, CUT HEIGHT

AVENUE/BOULEVARD

FRONT & REAR TIRES
{AVENUE}

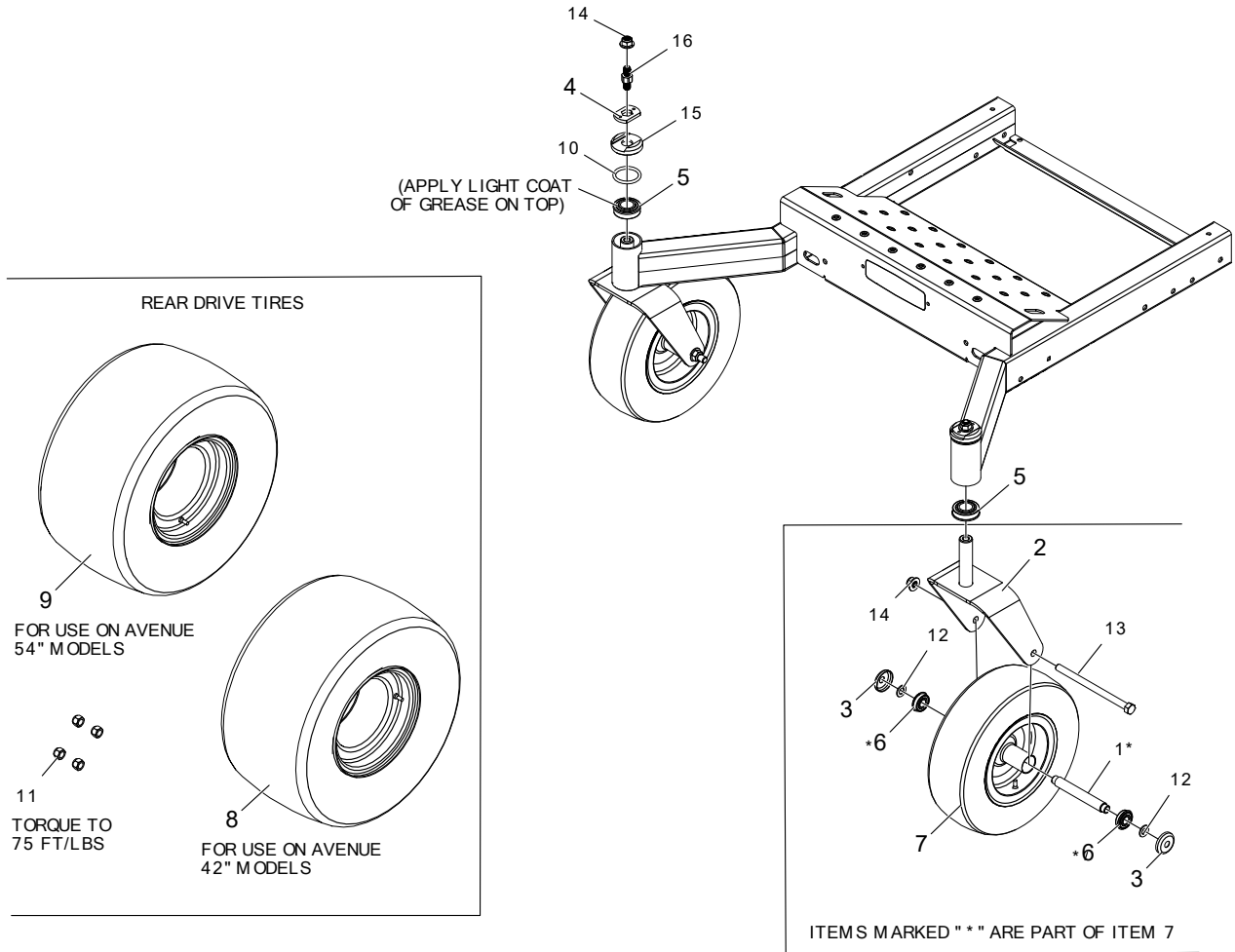

ITEM #	QTY	PART #	DESCRIPTION
1	2	714-225P	SPACER, CASTER BEARING
2	2	714-227W	WLDT, CASTER YOKE
3	4	714-277P	CAP, BEARING, SMALL
4	2	714-589P	CASTER BRAKE DRIVE WASHER
5	4	D-2008-02	BEARING, SPD, SF-16-32
6	4	D-3432	BEARING, 5/8 I.D. X 1-3/8 O.D.
7	2	D-4027	TIRE ASSY, 13 X 5-6, BLACK, SM BEARING, SMOOTH
8	2	D-4028	TIRE, 18 X 8.5-8 TURFMASTER, BLACK
9	2	D-4029	TIRE, 18 X 9.50-8, TURF MASTER, BLACK
10	2	D-4217	CASTER BRAKE, O-RING
11	8	F-1499	LUG NUT, 1/2-20, YZ
12	4	F-1521	WASHER, 1/2" CUSTOM, YZ
13	2	F-1663	HHCS, 1/2-13 X 7-1/2", YZ, GR5
14	2	F-2152	NUT, 1/2-13 NYLOC, FLANGED, YZ
15	2	H-3267	CASTER BRAKE CAP
16	2	H-3268	CASTER BRAKE ADJUSTER

AVENUE/BOULEVARD

FRONT & REAR TIRES
{BOULEVARD}

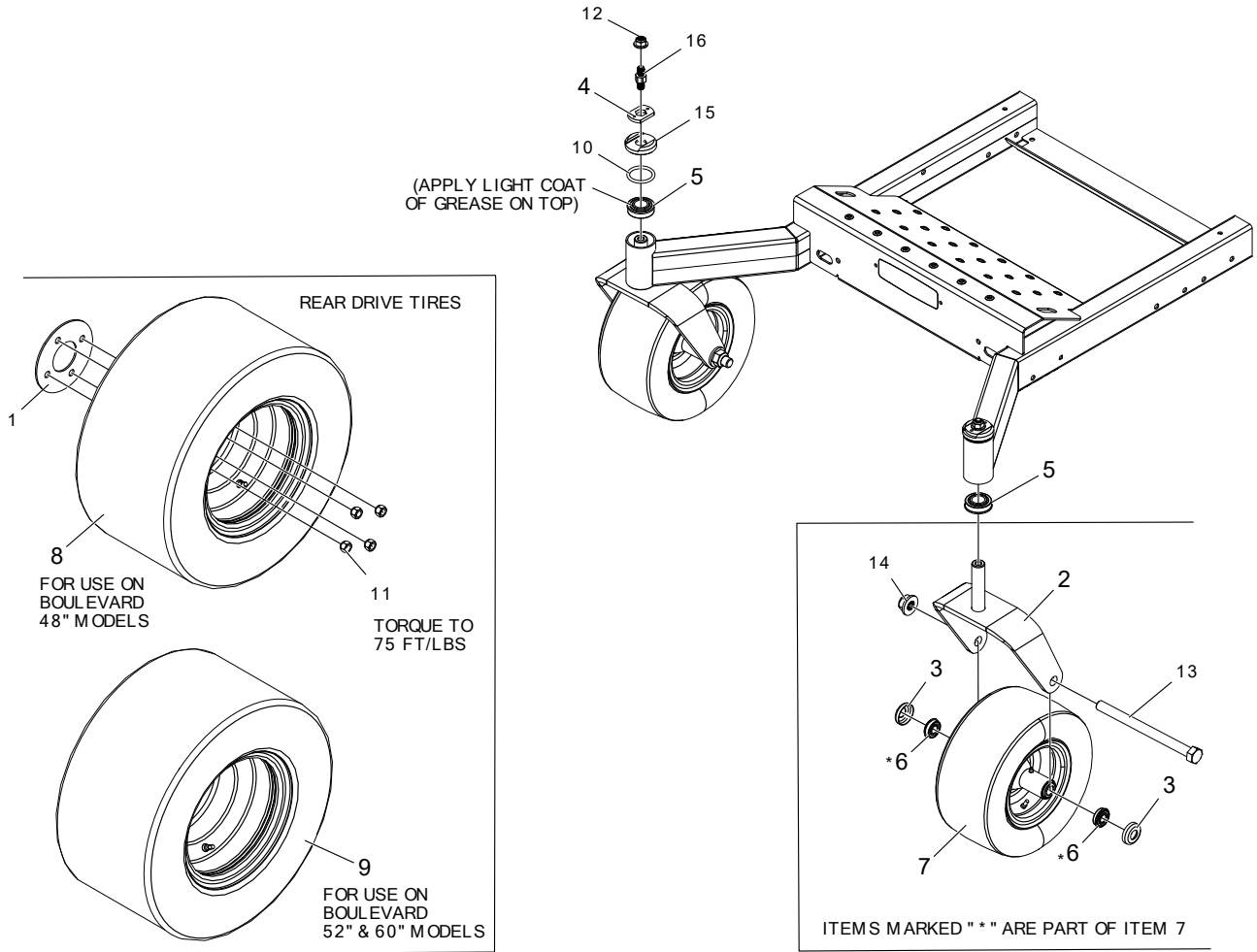

ITEM #	QTY	PART #	DESCRIPTION
1	2	659-092P	WHEEL BACKING PLATE
2	2	714-219W	WLDT, CASTER YOKE
3	4	714-252P	CAP, BEARING, SMALL, 3/4"
4	2	714-589P	CASTER BRAKE DRIVE WASHER
5	4	D-2008-02	BEARING, SPD, SF-16-32
6	4	D-3978	BEARING FOR D-4030
7	2	D-4030	TIRE ASSY, 13 X 6.5-6, BLACK, SM BEARING, SMOOTH
8	2	D-4031	TIRE ASSY, 20 X 10-10, BLACK
9	2	D-4032	TIRE ASSY 20 X 12-10, BLACK
10	2	D-4217	CASTER BRAKE, O-RING
11	8	F-1499	LUG NUT, 1/2-20, YZ
12	2	F-2152	NUT, 1/2-13 NYLOC, FLANGED, YZ
13	2	F-2194	HHCS, 3/4-10 X 9-1/2", YZ, GR5
14	2	F-2195	NUT, FLANGE NYLOC, YZ
15	2	H-3267	CASTER BRAKE CAP
16	2	H-3268	CASTER BRAKE ADJUSTER

AVENUE/BOULEVARD

FRONT PANEL ASSEMBLY & RELATED PARTS

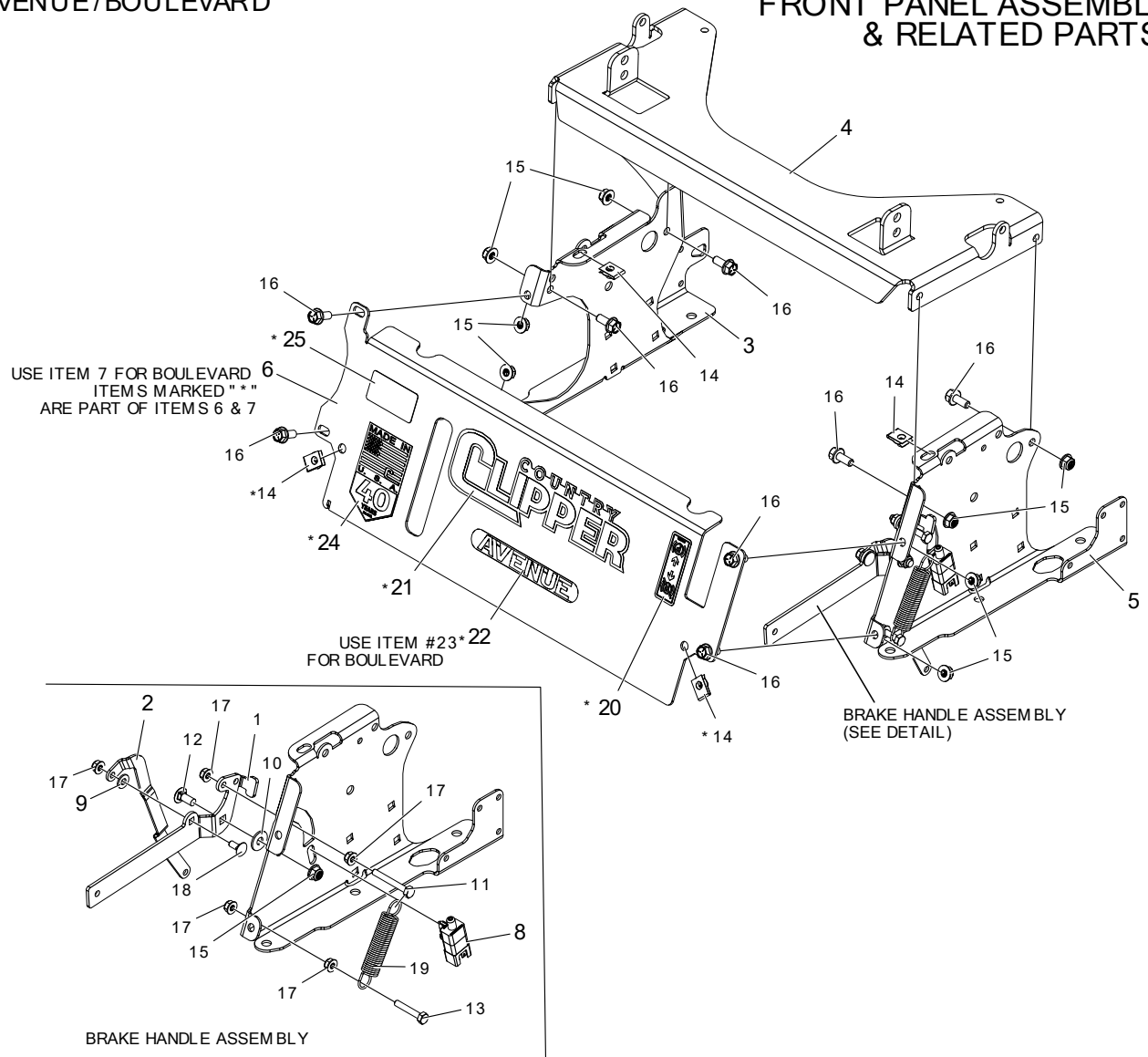

ITEM #	QTY	PART #	DESCRIPTION
1	1	714-503P	BRAKE HANDLE, OFFSET
2	1	714-512P	BRAKE LINK
3	1	714-532P	SIDE PANEL, RH
4	1	714-536P	SEAT MOUNT, HINGED
5	1	714-538P	SIDE PANEL, LH
6	1	714-596A	FRONT PANEL W/ DECALS, (AVE)
7	1	714-597A	FRONT PANEL W/ DECALS, (BLVD)
8	1	E-6692	PLUNGER SWITCH, RAIL MOUNT
9	1	F-1009-01	FLAT WASHER, 1/4", YZ
10	1	F-1009-02	WASHER, FLAT, 5/16
11	1	F-1015-09	HHCS, 1/4-20 X 2", YZ, GR5
12	1	F-1671	CARRIAGE BOLT, 5/16-18 X 3/4", YZ, GR5
13	1	F-1716	CAPSCREW HX 1/4-20 X 1-1/2", GR5, YZ

ITEM #	QTY	PART #	DESCRIPTION
14	4	F-1858	U-NUT, 1/4-20
15	9	F-2063	NUT, 5/16-18, NYLOC, FLANGED, YZ
16	8	F-2120	FHCS, 5/16-18 X 3/4", YZ, GR5
17	5	F-2132	NUT, 1/4-20 NYLOC, FLANGED, YZ
18	1	F-2155	BOLT, CARRIAGE, 1/4-20 X 5/8", YZ, GR5
19	1	H-1635	SPRING, EXT, 3/4" OD X 4" OAL
20	1	P-11382	DECAL, PARK BRAKE
21	1	P-13312	DECAL, LOGO, CHROME w/BLK, LG
22	1	P-13313	DECAL, AVENUE
23	1	P-13314	DECAL, BOULEVARD
24	1	P-13682	DECAL, 40TH ANNIVERSARY
25	1	P-13748	DECAL, FUEL SAFETY

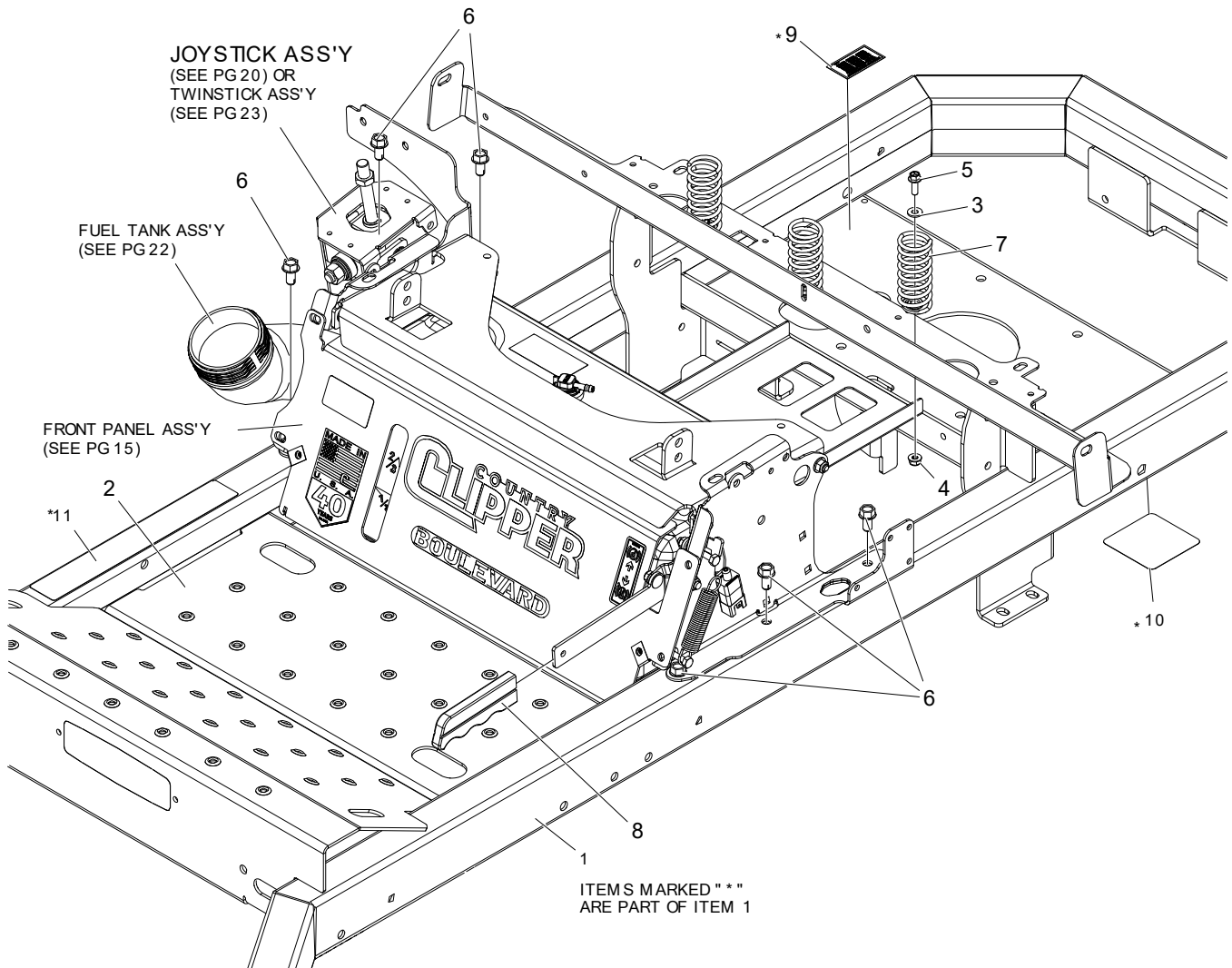

ITEM #	QTY	PART #	DESCRIPTION
1	1	714-600A	WLDT, FRAME W/ DECALS
2	1	720-095P	FLOOR PAN
3	3	F-1009-01	WASHER, FLAT STD, STEEL, 1/4" YELLOW PLATED
4	3	F-2132	NUT, 1/4-20 NYLOC, FLANGED, YZ
5	3	F-2162	FHCS, 1/4-20 X 3/4", YZ, GR5
6	4	F-2219	HFCS, 3/8-16 X 3/4", CZ, THD FORMING
7	3	H-1920	SPRING, SEAT
8	1	H-1926	1/4" X 1" HANDLE GRIP
9	1	P-10777	DECAL, "PATENT"
10	1	P-12918	DECAL, HYDRO BELT ROUTING
11	1	P-13751	DECAL, SAFTEY

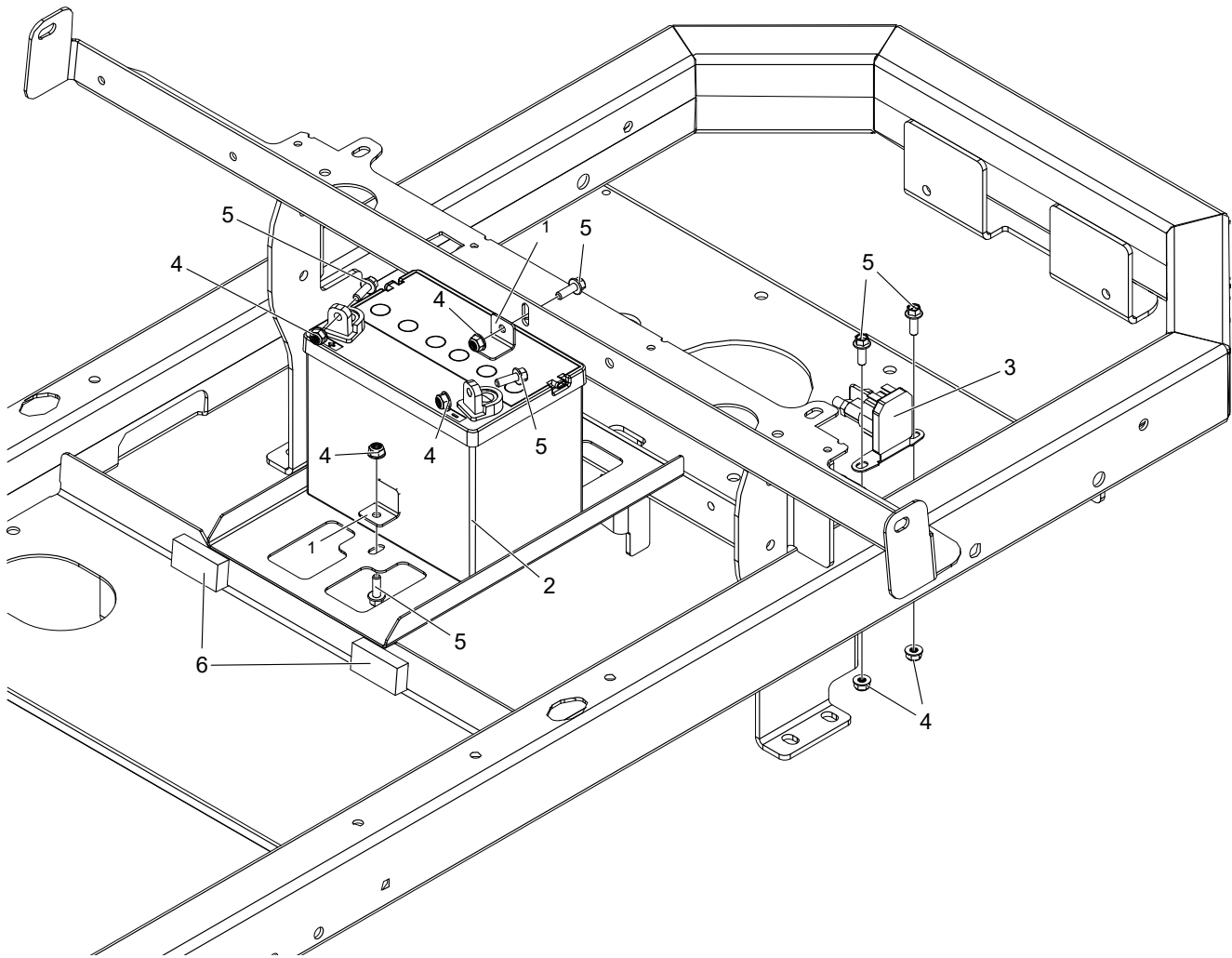

ITEM #	QTY	PART #	DESCRIPTION
1	1	714-513P	BATTERY CLIP
2	1	E-6604	BATTERY, 12V, 150CCA
3	1	E-6612	SOLENOID, 12V STARTER, 4 TERM, UNSEALED
4	6	F-2132	NUT, 1/4-20 NYLOC, FLANGED, YZ
5	6	F-2162	FHCS, 1/4-20 X 3/4", YZ, GR5
6	2	H-2990	WEATHER-RESISTANT NEOPRENE FOAM (ADHESIVE) 1/2"

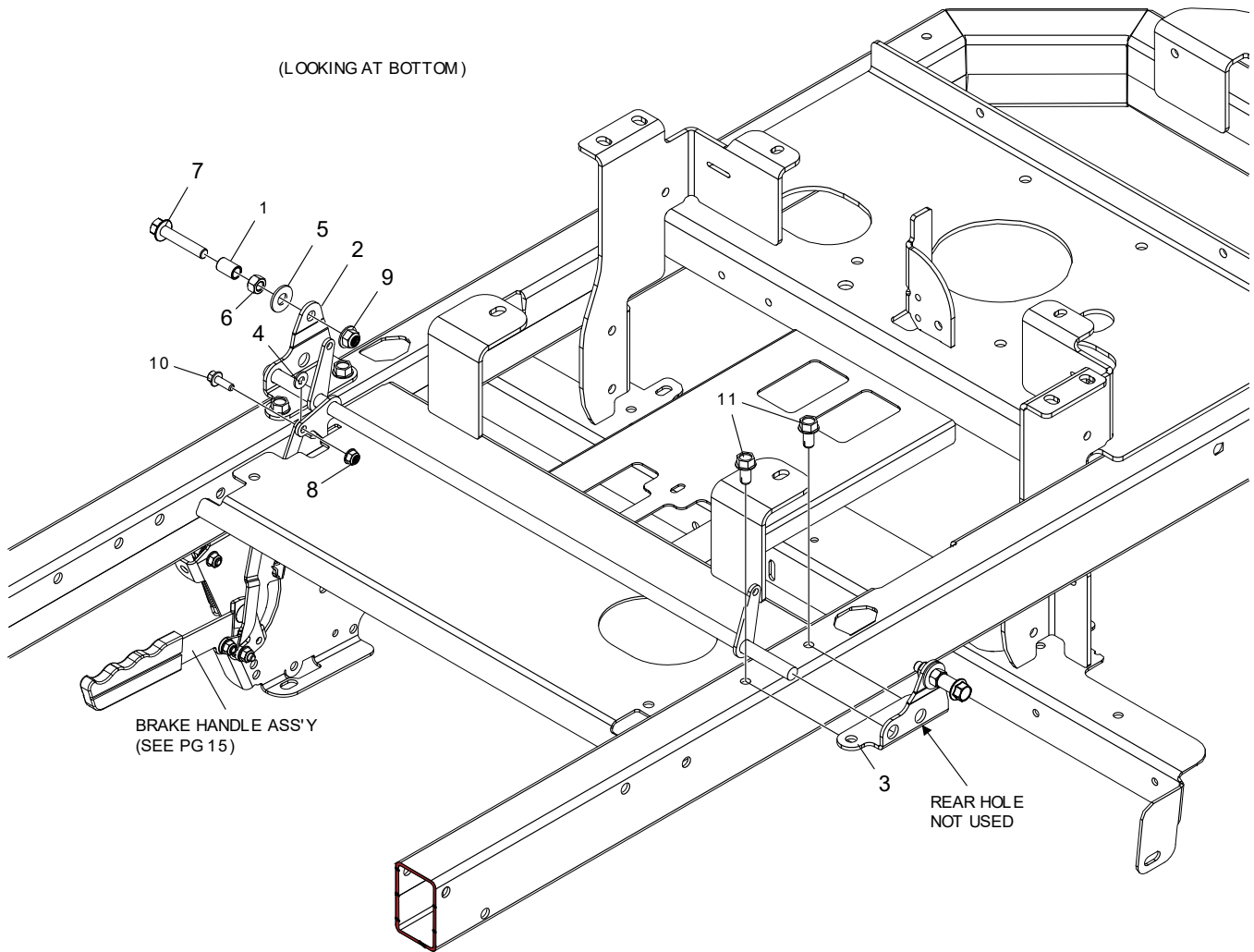

ITEM #	QTY	PART #	DESCRIPTION
1	2	707-073P	STAND-OFF, LINKAGE MOUNT
2	1	714-473P	BRACKET, DECK FLIP & BRAKE ROD HANGER, LH
3	1	714-501P	BRACKET, DECK FLIP & BRAKE ROD HANGER, RH
4	1	F-1009-01	FLAT WASHER, 1/4", YZ
5	2	F-1009-03	WASHER, FLAT, 3/8, YZ
6	2	F-1011-03	NUT, HEX, 3/8-16, YZ
7	2	F-2126	FHCS, 3/8-16 X 2", YZ, GR5
8	1	F-2132	NUT, 1/4-20 NYLOC, FLANGED, YZ
9	2	F-2151	NUT, 3/8-16 NYLOC, FLANGED
10	1	F-2162	FHCS, 1/4-20 X 3/4", YZ, GR5
11	4	F-2219	HFCS, 3/8-16 X 3/4", CZ, THD FORMING

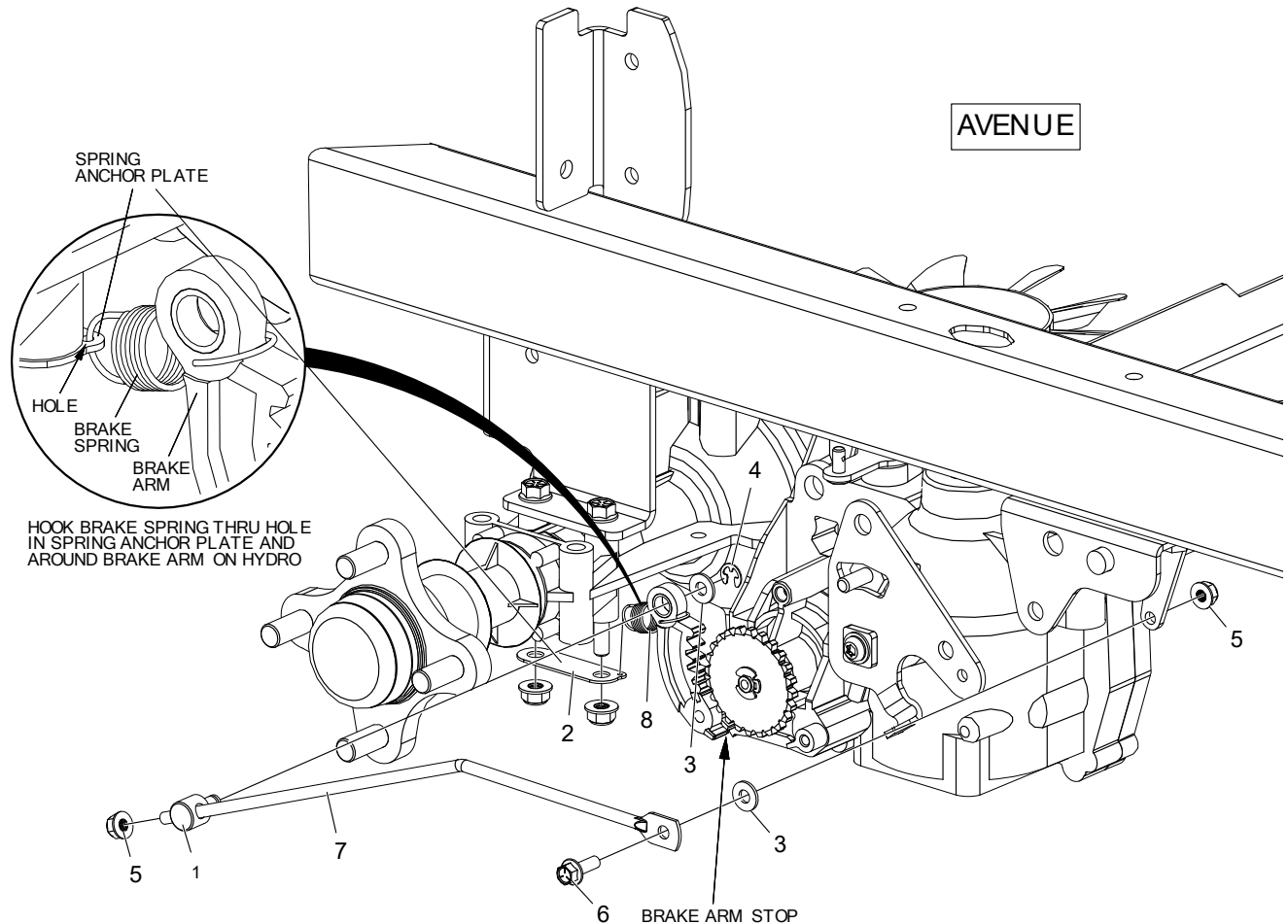

HOOK BRAKE SPRING THRU HOLE IN SPRING ANCHOR PLATE AND AROUND BRAKE ARM ON HYDRO

IMPORTANT!!
 WITH THE BRAKES OFF AND THE BRAKE ARM TOUCHING THE BRAKE ARM STOP, TIGHTEN ADJUSTMENT NUT, ITEM 5 UNTIL IT JUST CONTACTS THE BRAKE STUD, ITEM 1
 WITH BRAKES SET, BRAKE ARM TEETH SHOULD FULLY ENGAGE THE GEAR SPROCKET TEETH.

ITEM #	QTY	PART #	DESCRIPTION
1	2	714-522P	BRAKE STUD
2	2	714-581P	BRAKE SPRING ANCHOR PLATE
3	4	F-1009-01	FLAT WASHER, 1/4", YZ
4	2	F-1610	RETAINING RING, EXTERNAL
5	4	F-2132	NUT, 1/4-20 NYLOC, FLANGED, YZ
6	2	F-2162	FHCS, 1/4-20 X 3/4", YZ, GR5
7	2	H-3250	BRAKE LINK ROD
8	2	H-3263	BRAKE BIAS SPRING

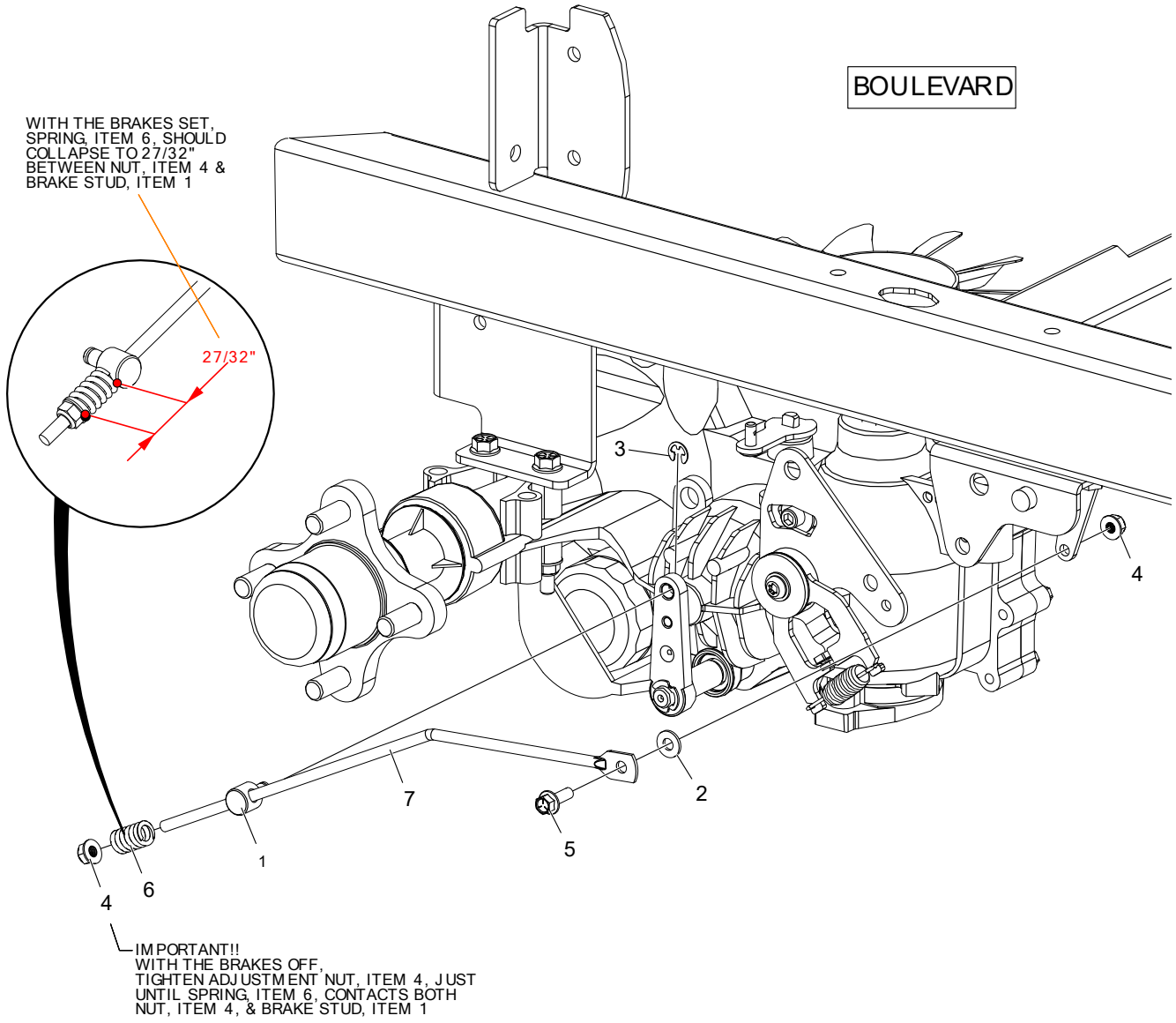

ITEM #	QTY	PART #	DESCRIPTION
1	2	714-522P	BRAKE STUD
2	2	F-1009-01	FLAT WASHER, 1/4", YZ
3	2	F-1610	RETAINING RING, EXTERNAL
4	2	F-2132	NUT, 1/4-20 NYLOC, FLANGED, YZ
5	2	F-2162	FHCS, 1/4-20 X 3/4", YZ, GR5
6	2	H-2786	SPRING, COMP, 0.562 X 0.88 HGT
7	2	H-3250	BRAKE LINK ROD

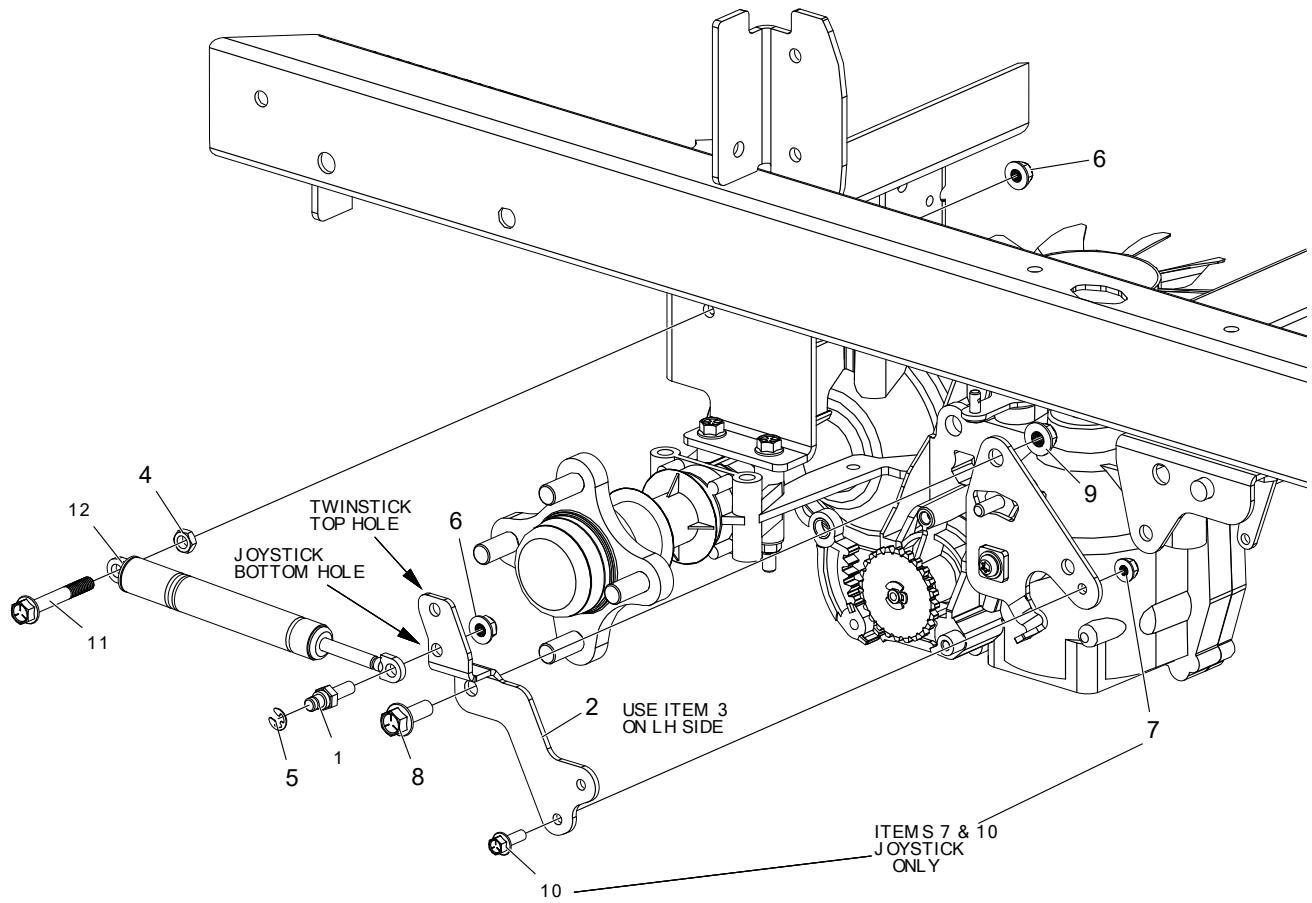

ITEM #	QTY	PART #	DESCRIPTION
1	1	638-028P	DAMPER BOLT 5/16-18 X 3/4"
2	1	721-122P	BRACKET, DAMPER OFFSET, RH
3	1	721-121P	BRACKET, DAMPER OFFSET, LH
4	2	F-1011-02	NUT, HEX 5/16-18
5	2	F-1610	RETAINING RING, EXTERNAL
6	4	F-2063	NUT, 5/16-18, NYLOC, FLANGED, YZ
7	2	F-2132	NUT, 1/4-20 NYLOC, FLANGED, YZ
8	2	F-2141	FHCS, 3/8-16 X 1", YZ, GR5
9	2	F-2151	NUT, 3/8-16 NYLOC, FLANGED, YZ
10	2	F-2162	FHCS, 1/4-20 X 3/4", YZ, GR5
11	2	F-2248	FHCS, 5/16-18 X 2-1/4", YZ, GR8
12	2	H-2896	DAMPER

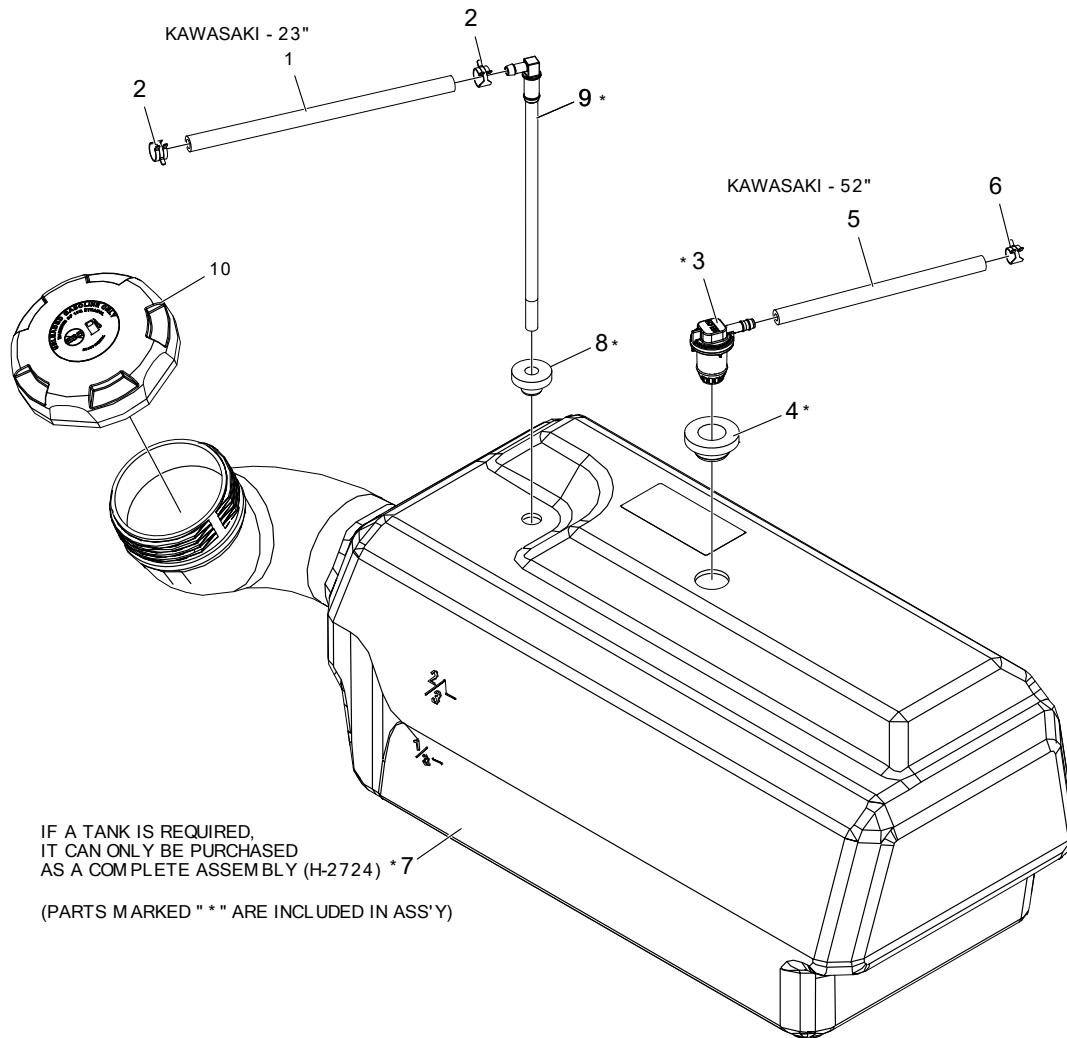

ITEM #	QTY	PART #	DESCRIPTION
1	1	H-1648	FUEL LINE, 1/2" O.D., 1/4" I.D.
2	2	H-1687	1/2 O.D. HOSE SPRING CLAMP
3	1	H-2831	REMOTE VENT
4	1	H-2679	REMOTE VENT GROMMET
5	1	H-2697	HOSE, FUEL LINE .188 ID X .406 OD
6	1	H-2698	CLAMP, .406 OD FUEL LINE
7	1	H-2724	ASSEMBLY, FUEL TANK, SMALL
8	1	H-2741	GROMMET, PICK UP TUBE
9	1	H-2742	PICK UP TUBE
10	1	H-3236	RATCHET CAP, W/ SS TETHER, 3.5 DIA

JOYSTICK CONTROL & RELATED PARTS

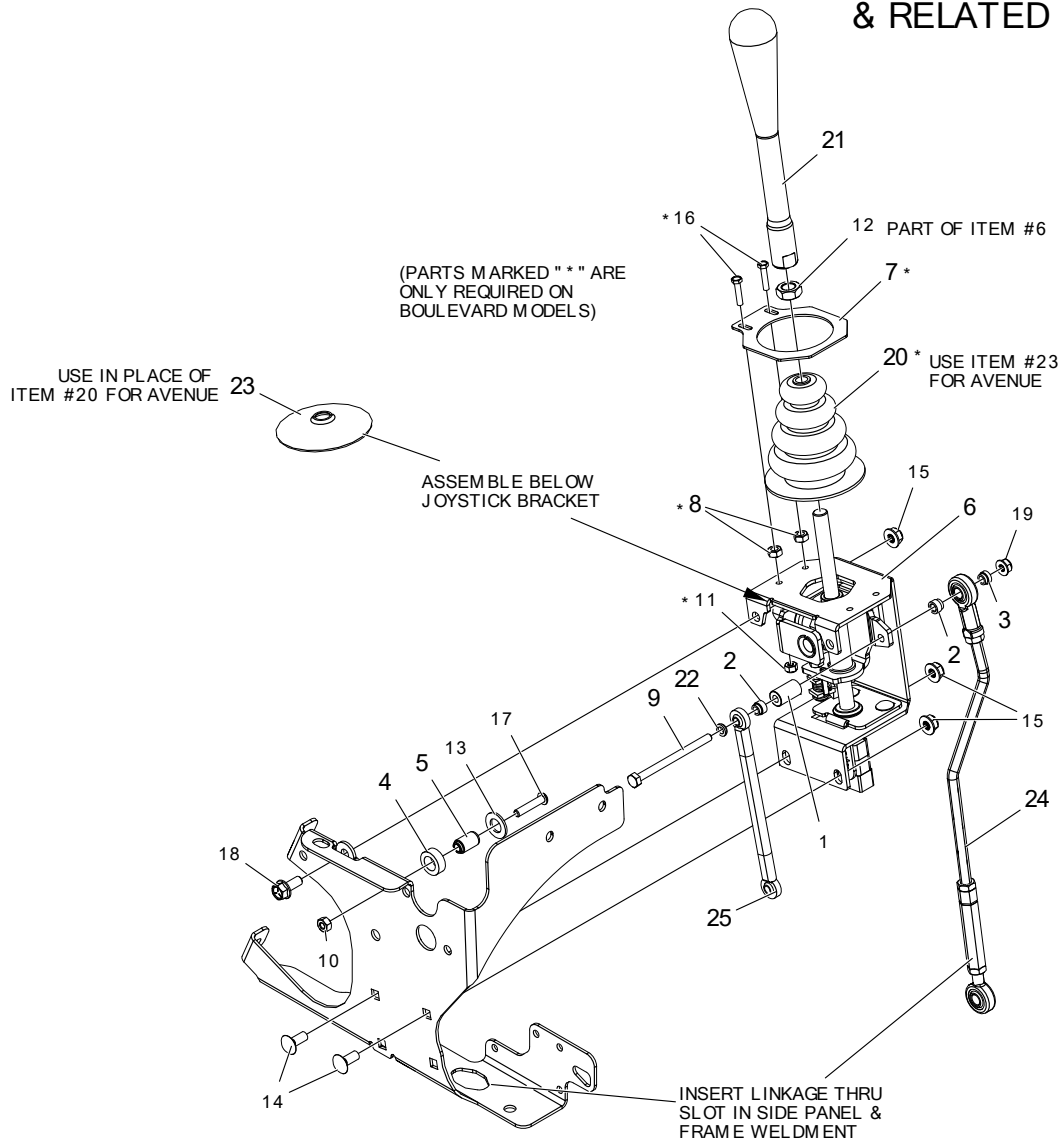

ITEM #	QTY	PART #	DESCRIPTION
1	1	625-100P	TUBE, PIVOT, JOYSTICK
2	1	625-107P	BUSHING, .375 ROD END
3	2	625-116P	BUSHING, .375 ROD END, SHORT
4	1	625-126P	SPACER, JOYSTICK PANEL
5	1	714-544P	PIVOT PIN
6	1	714-595A	RH JOYSTICK ASSEMBLY
7	1	720-038P	PLT, BOOT RETAINER
8	2	F-1011-01	NUT, HEX, 1/4-20 UNC-2B YELLOW PLATED
9	1	F-1020-01	CAPSCREW, 1/4-20 X 3-1/2", YZ, GR5
10	1	F-1158	NUT, CENTERLOCK, 1/4-20, YZ, GR5
11	2	F-1448	LOCKNUT, 10-32 NYLOC YELLOW PLTD
12	1	F-1462	JAM NUT, 1/2-20, RH, YZ
13	1	F-1521	WASHER, 1/2" CUSTOM, YZ
14	2	F-1671	CARRIAGE BOLT, 5/16-18 X 3/4", GR5, YZ
15	3	F-2063	NUT, 5/16-18, NYLOC, FLANGED, YZ
16	2	F-2100	HHMS, 10-32 X 7/8", CZ
17	1	F-2103	SHCS, BUTTON HD, 1/4-20 X 1-1/4", CZ
18	1	F-2120	FHCS, 5/16-18 X 3/4", YZ, GR5
19	1	F-2132	NUT, 1/4-20 NYLOC, FLANGED, YZ
20	1	H-1991	JOY STICK BOOT
21	1	H-2964	HANDLE, JOYSTICK
22	1	H-1989	BUSHING BALL JOINT
23	1	H-2947	BOOT, LOW PROFILE
24	1	H-3226	LINKAGE ASSEMBLY, JS, RH
25	1	H-3229	LINKAGE INNER, 1/4 X 6.375

AVENUE/BOULEVARD

JOYSTICK ASSEMBLY
{714-595A}

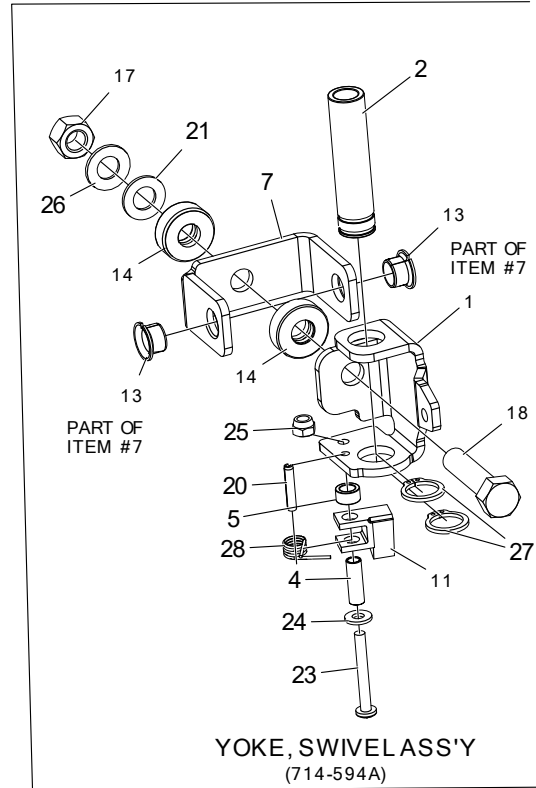
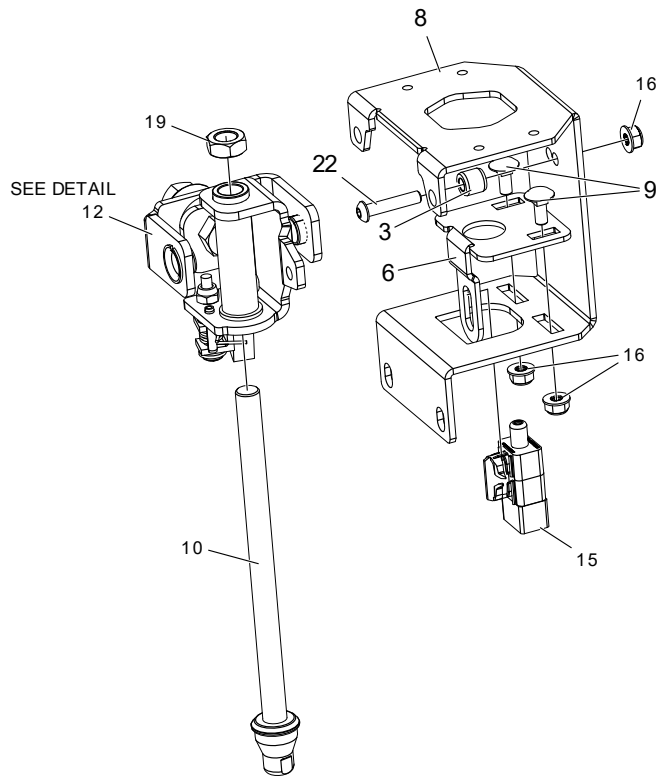

ITEM #	QTY	PART #	DESCRIPTION
1	1	625-096P	YOKE, SWIVEL, JOYSTICK
2	1	625-099P	TUBE, GUIDE, CONTROL ROD
3	1	625-106P	PIN, PIVOT, JS
4	1	625-124P	TUBE-SPACER, DETENT CAM
5	1	625-125P	SPACER, CAM DETENT
6	1	724-114P	JOYSTICK NEUTRAL PLATE
7	1	625-128A	PIVOT ASSEMBLY
8	1	724-113P	JOYSTICK HOUSING
9	2	F-2155	BOLT, CARRIAGE, 1/4-20 X 5/8", YZ, GR5
10	1	709-169A	ROD ASSEMBLY, SHORT, 1/2"
11	1	714-593P	TAB, CAM DETENT
12	1	714-594A	YOKE, SWIVEL ASSEMBLY
13	2	D-3784	BUSHING, DU 1/2 DIA X 3/8 WIDE
14	2	D-3931	THRUST BEARING
15	1	E-6692	PLUNGER SWITCH, RAIL MOUNT
16	3	F-2132	NUT, FLANGED, 1/4-20 w/NYLOC, YZ
17	1	F-1005-05	NUT, 1/2-13, CENTERLOCK, YZ, GR5
18	1	F-1293	HHCS, 1/2-13 X 2", YZ, GR5
19	1	F-1462	JAM NUT, 1/2-20, RH, YZ
20	1	F-1503	PIN, SPIROL 3/16 DIA X 1 X .010 THK
21	1	F-1521	WASHER, 1/2" CUSTOM, YZ
22	1	F-2103	SHCS, BUTTON HD, 1/4-20 X 1", CZ
23	1	F-2135	SCREW, PANHEAD, PHILLIPS #12-24 X 1.75 CZ
24	1	F-2136	WASHER, FLAT, #12 PLAIN, CZ
25	1	F-2137	NUT, #12-24, NYLOCK
26	1	H-2704	SPRING, BELLEVILLE, .50 X 1 X .073
27	2	H-2705	RING, RETAINING, .75 EXT.
28	1	H-2710	SPRING, DETENT, JOYSTICK

JOYSTICK ASSEMBLY MOUNTING
& RELATED PARTS

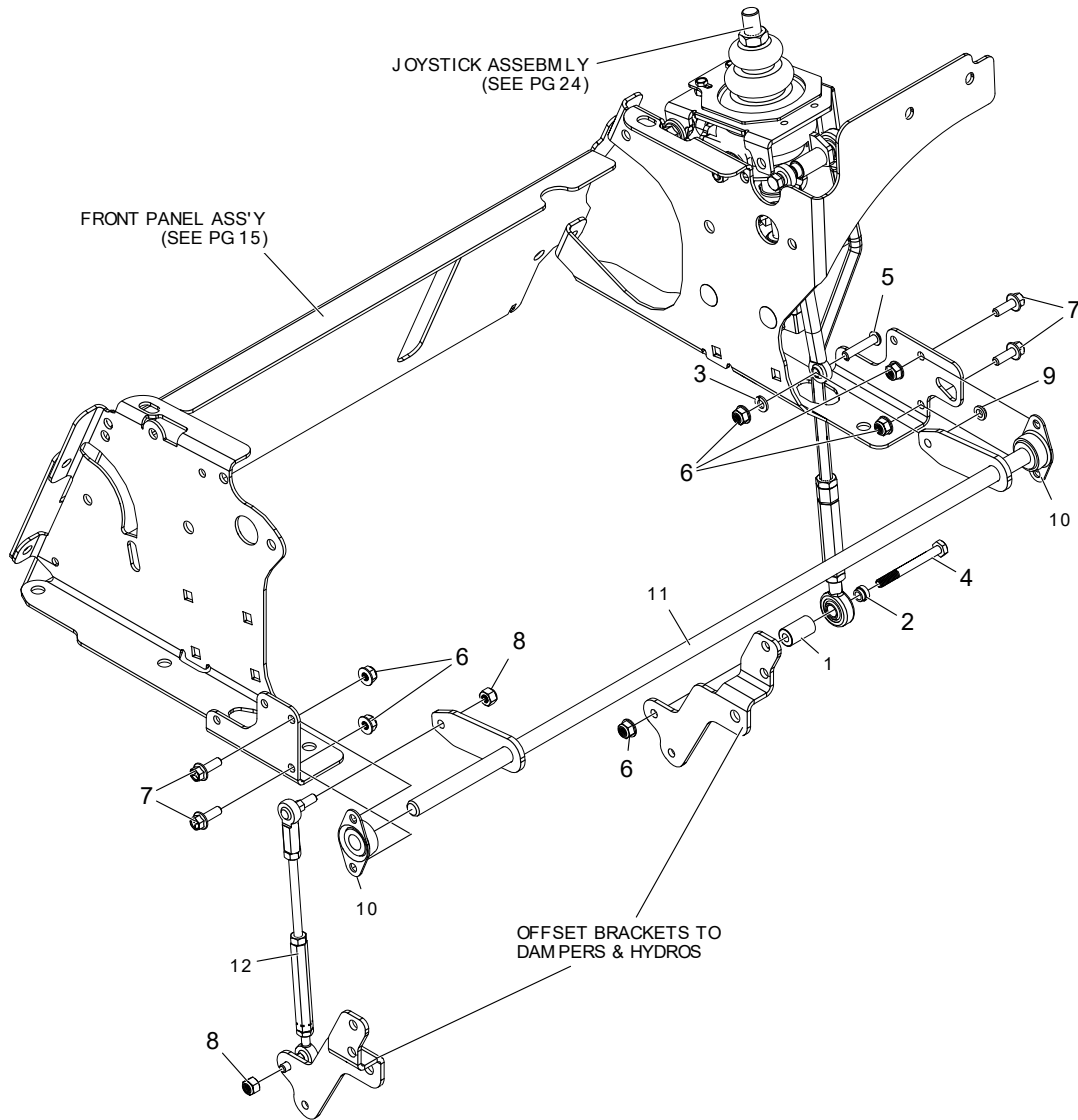

ITEM #	QTY	PART #	DESCRIPTION
1	1	625-100P	TUBE, PIVOT, JOYSTICK
2	1	625-116P	BUSHING, .375 ROD END, SHORT
3	1	F-1019-01	WASHER, LOCK, 1/4, YZ
4	1	F-1703	CAPSCREW, HEX HD 1/4-20 X 2-1/2"
5	1	F-2103	BUTTON SHCS, 1/4-20 X 1.25
6	6	F-2132	NUT, 1/4-20 NYLOC, FLANGED, YZ
7	4	F-2162	FHCS, 1/4-20 X 3/4", YZ, GR5
8	2	F-2202	NUT, 1/4-20, NYLOC, YZ
9	1	H-1989	BUSHING BALL JOINT
10	2	H-2921	FLANGE BRG., 0.500
11	1	H-3221	WLDT. CROSS SHAFT, JS
12	1	H-3234	CONTROL LINKAGE ASSEMBLY

TWIN LEVER CONTROL & RELATED PARTS

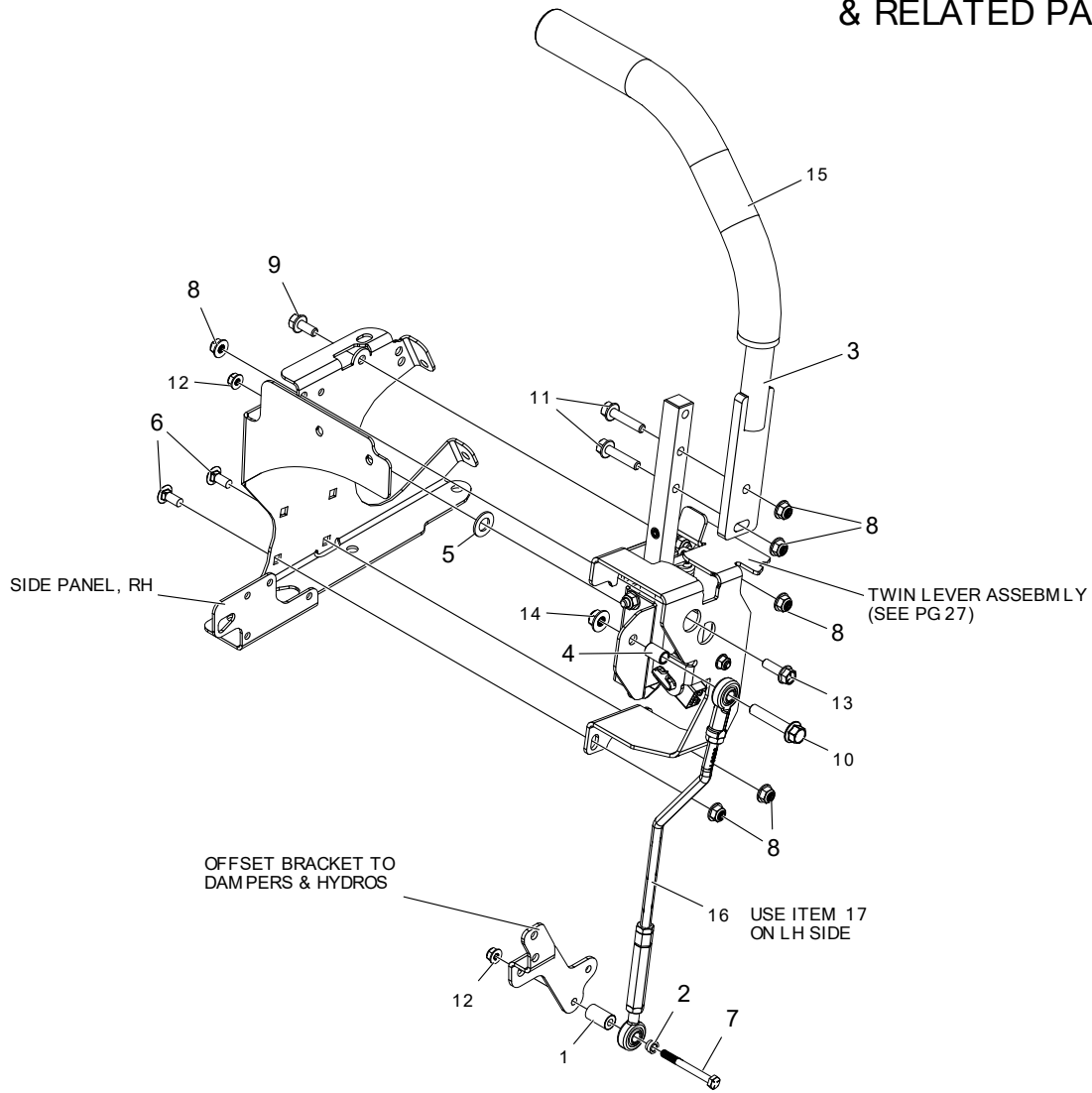

ITEM #	QTY	PART #	DESCRIPTION
1	1	625-100P	TUBE, PIVOT, JOYSTICK
2	1	625-116P	BUSHING, .375 ROD END, SHORT
3	2	659-375W	WLDT, DUAL LEVER
4	1	707-073P	STAND-OFF, LINKAGE MOUNT
5	1	F-1521	WASHER, 1/2" CUSTOM, YZ
6	2	F-1671	CARRIAGE BOLT, 5/16-18 X 3/4", YZ, GR5
7	1	F-1703	CAPSCREW, 1/4-20 X 2-1/2, GR5, ZC
8	6	F-2063	NUT, 5/16-18, NYLOC, FLANGED, YZ
9	1	F-2120	FHCS, 5/16-18 X 3/4", YZ, GR5
10	1	F-2126	FHCS, 3/8-16 X 2", YZ, GR5
11	2	F-2129	FHCS, 5/16-18 X 1-1/2", YZ, GR5
12	2	F-2132	NUT, 1/4-20 NYLOC, FLANGED, YZ
13	1	F-2148	FHCS, 5/16-18 X 1", YZ, GR5
14	1	F-2151	NUT, 3/8-16 NYLOC, FLANGED, YZ
15	1	H-2739	GRIP, 15", CLOSED END
16	1	H-3226	LINKAGE ASSEMBLY, TS, RH
17	1	H-3227	LINKAGE ASSEMBLY, TS, LH

TWIN LEVER ASSEMBLY
 {714-546A - RIGHT HAND}
 {714-547A - LEFT HAND}

RIGHT HAND SHOWN
 LEFT HAND OPPOSITE

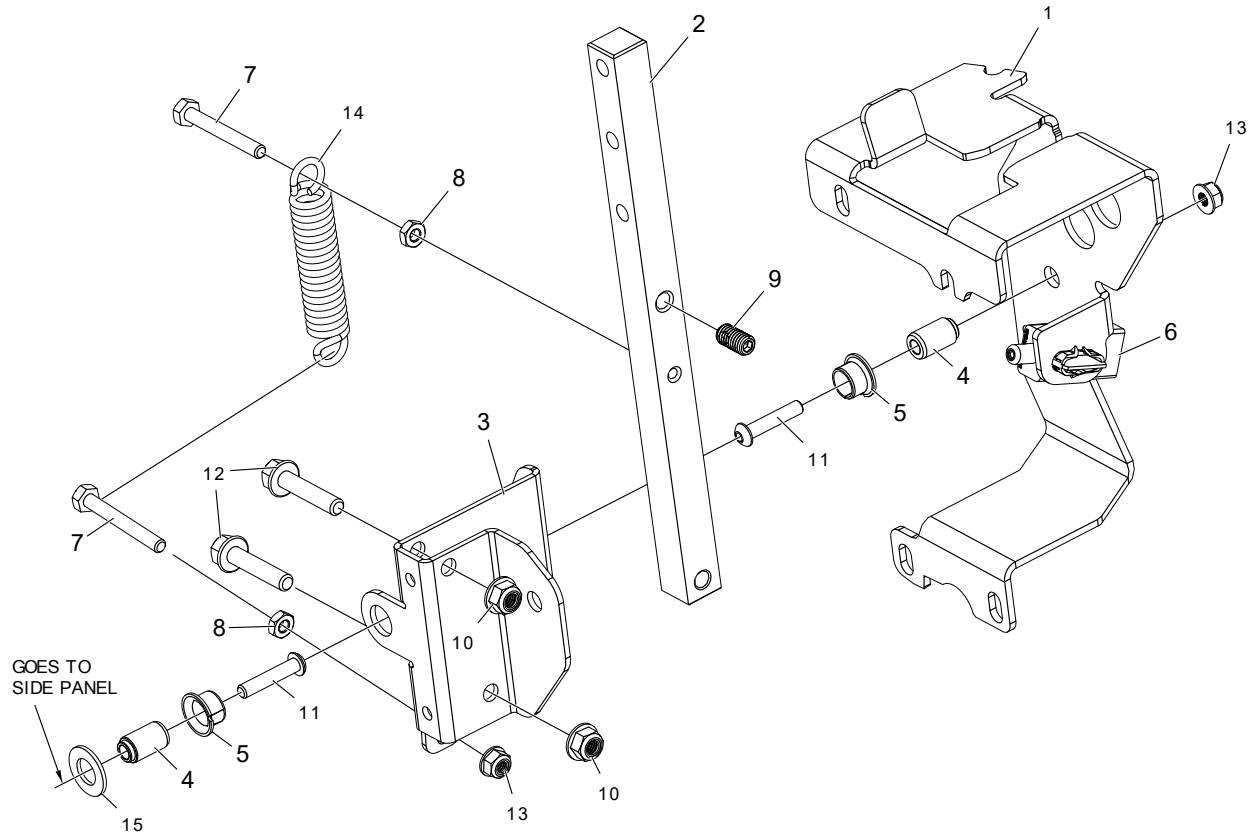

ITEM #	QTY	PART #	DESCRIPTION
1	1	714-539P	HOUSING, TWINSTICK, RH
-	1	714-540P	HOUSING, TWINSTICK, LH
2	1	714-541P	HANDLE BASE LEVER, TS
3	1	714-542P	PIVOT CHANNEL, RH
-	1	714-543P	PIVOT CHANNEL, LH
4	2	714-544P	PIVOT PIN
5	2	D-3784	BUSHING, DU 1/2 DIA X 3/8 WIDE
6	1	E-6692	PLUNGER SWITCH, RAIL MOUNT
7	2	F-1015-09	HHCS, 1/4-20 X 2", YZ, GR5
8	2	F-1011-01	NUT, HEX, 1/4-20, YZ
9	1	F-1903	SETSCREW, 3/8-16 X 3/4" W/ NYLON
10	2	F-2063	NUT, 5/16-18, NYLOC, FLANGED, YZ
11	2	F-2103	SHCS, BUTTON HD, 1/4-20 X 1", CZ
12	2	F-2129	FHCS, 5/16-18 X 1-1/2", YZ, GR5
13	2	F-2132	NUT, 1/4-20 NYLOC, FLANGED
14	1	H-3271	OVER-CENTER SPRING, TWINSTICK
15	1	F-1521	WASHER, 1/2", TYPE B, NARROW, YZ

AVENUE/BOULEVARD

CONTROL PANEL

714-533A - BOULEVARD (KAW)
714-534A - AVENUE (KAW)

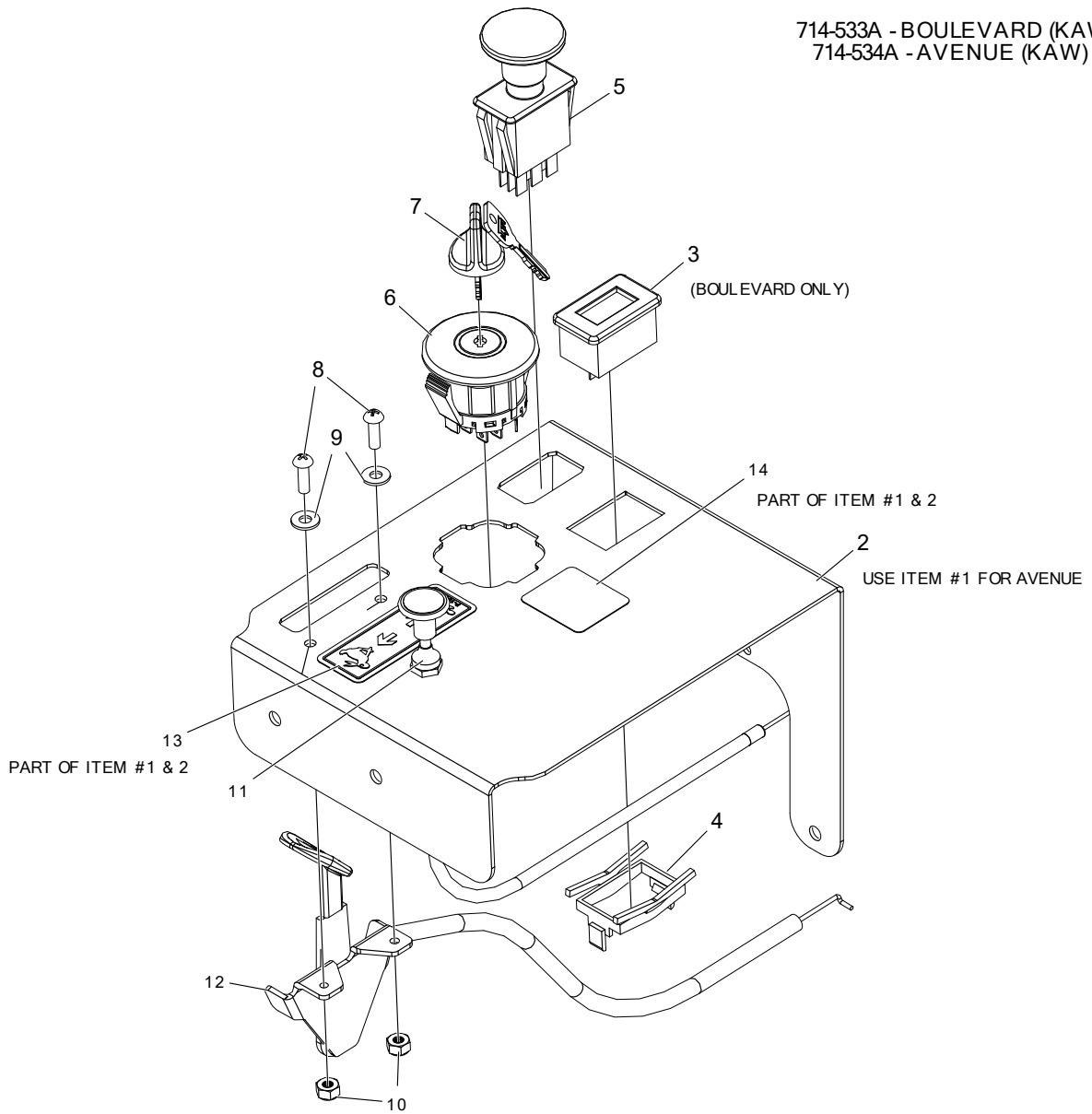

ITEM #	QTY	PART #	DESCRIPTION
1	1	714-598A	CONTROL PANEL W/ DECALS, (AVENUE)
2	1	714-599A	CONTROL PANEL W/ DECALS, (BOULEVARD)
3	1	E-5878	HOUR METER
4	1	E-6369	RETAINER CLIP
5	1	E-6403	PTO SWITCH
6	1	E-6717	IGNITION SWITCH, 4 POSITION
7	1	E-6718	KEY ASSEMBLY
8	2	F-1022-26	MACHINE SCREW, RND, 10-32 X 5/8, SLOTTED, CZ
9	2	F-1071	WASHER, FLAT #10, ZINC PLATED #10 SAE FLAT WASHER
10	2	F-1448	LOCKNUT, 10-32 NYLOC YELLOW PLTD
11	1	H-2287	CHOKE CABLE, 43-1/2"
12	1	H-2610	THROTTLE CABLE, 38", KAWASAKI
13	1	P-13481	DECAL, THROTTLE CONTROL
14	1	P-13750	DECAL, TAKE KEY

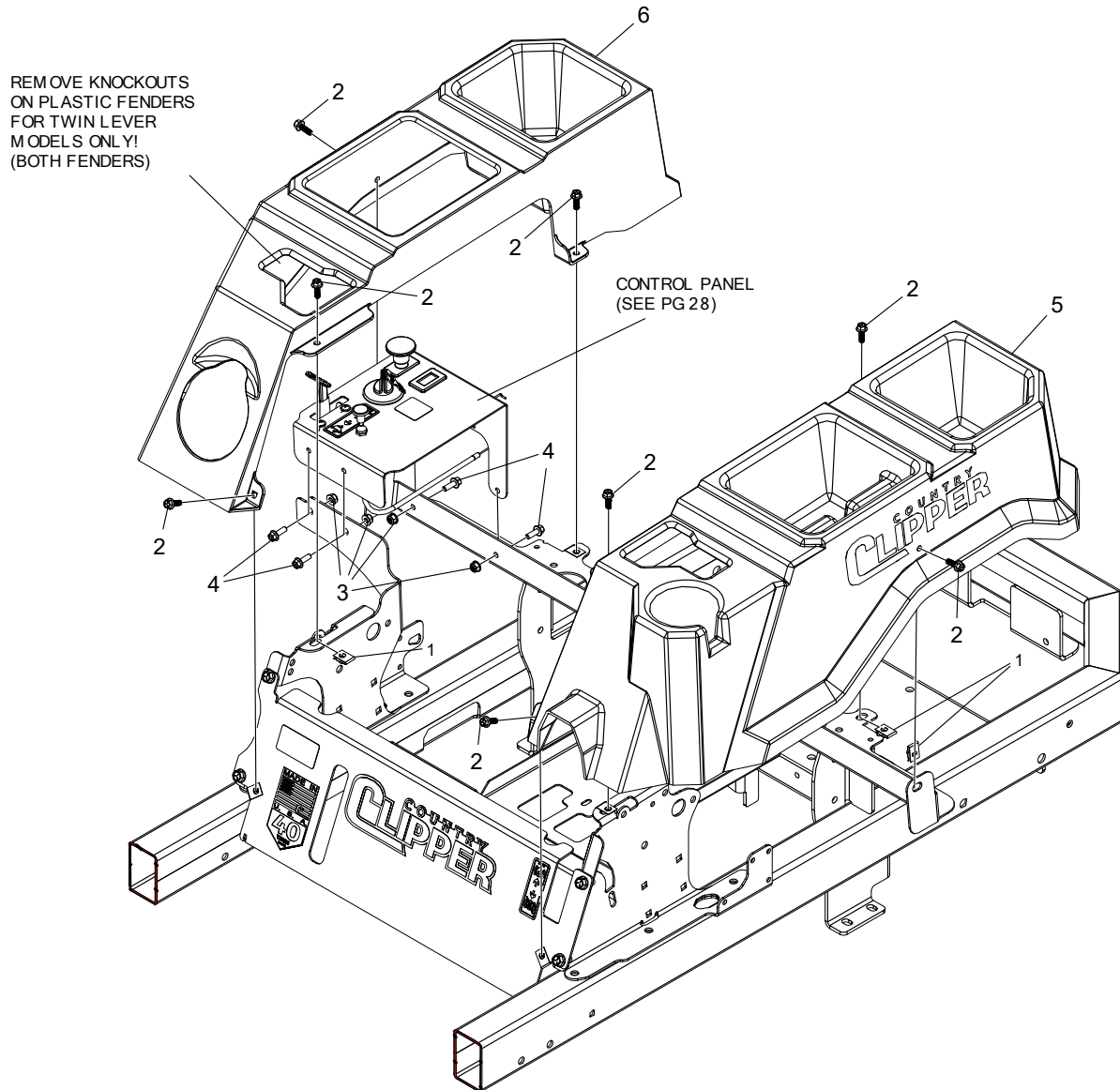

ITEM #	QTY	PART #	DESCRIPTION
1	4	F-1858	U-NUT, 1/4-20 THRD
2	8	F-2119	FHCS, 1/4-20 X 3/4", YZ, GR5, LOCK PATCH
3	4	F-2132	NUT, 1/4-20 NYLOC, FLANGED, YZ
4	4	F-2162	FHCS, 1/4-20 X 3/4", YZ, GR5
5	1	H-3251	FENDER, LH
6	1	H-3252	FENDER, RH

AVENUE / BOULEVARD

TRANSMISSION ASSEMBLY & RELATED PARTS

(LOOKING AT BOTTOM)

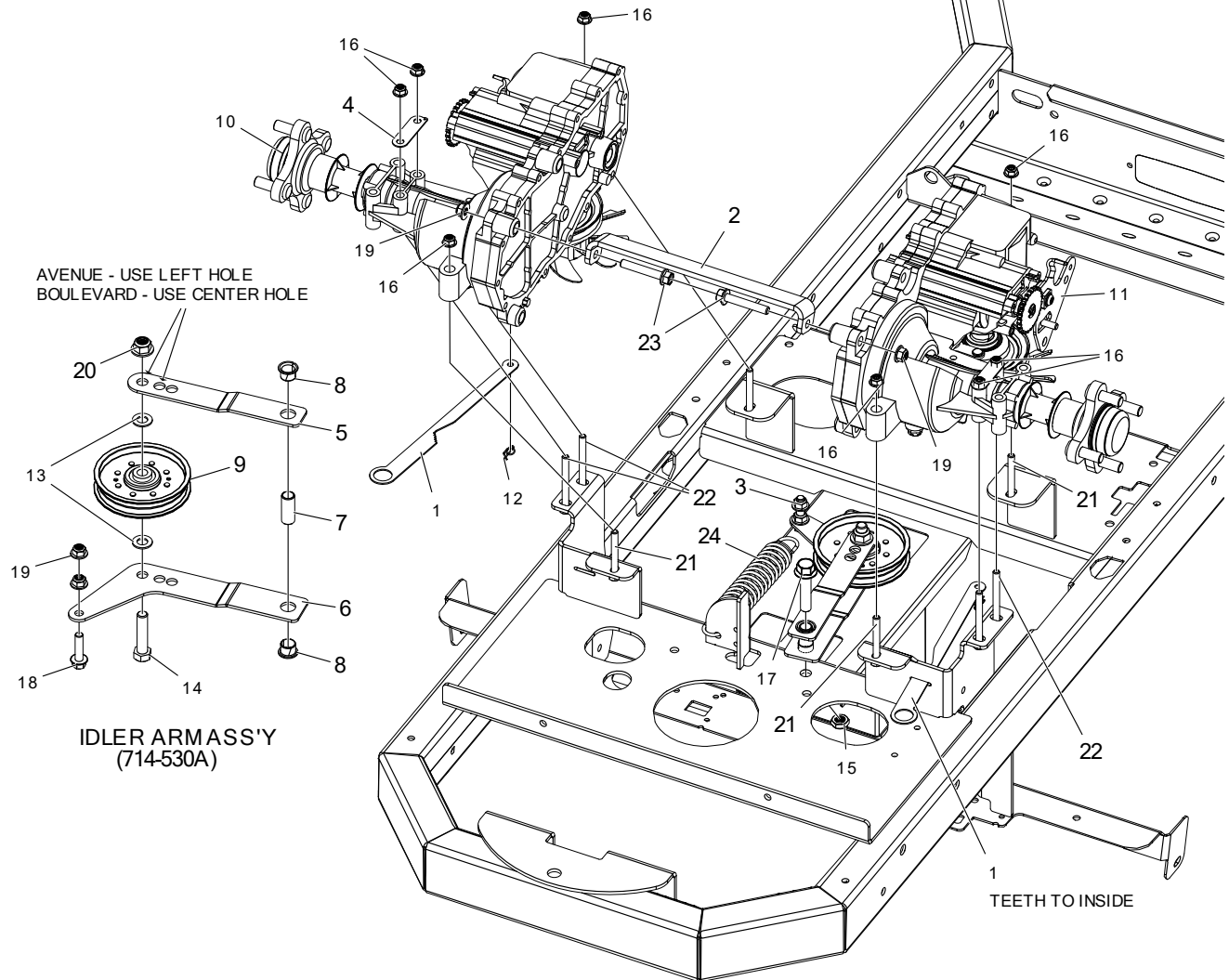

ITEM #	QTY	PART #	DESCRIPTION
1	2	714-454P	TAB, DUMP VALVE, COMMON
2	1	714-520P	HYDRO CROSS BRACE (AVENUE)
-	1	714-521P	HYDRO CROSS BRACE (BOULEVARD)
3	1	714-530A	IDLER SUB-ASSY
4	1	714-581P	BRAKE SPRING ANCHOR PLATE
5	1	714-592P	IDLER ARM, BOTTOM
6	1	720-145P	IDLER ARM, TOP
7	1	722-031P	MOUNTING PIN
8	2	D-3730	BUSHING, DU 5/8 DIA X 1/2 LG
9	1	D-3924	PULLEY, FLAT IDLER, 4.25 OD, NTN, DBL INSERT
10	1	D-4202-01	TRANSAXLE, ZT-2200, TOP FAN, TANKLESS, RH (AVENUE)
-	1	D-4199-01	TRANSAXLE, ZT-2800, TOP FAN, TANKLESS, RH (BOULEVARD)
11	1	D-4202-02	TRANSAXLE, ZT-2200, TOP FAN, TANKLESS, LH (AVENUE)
-	1	D-4199-02	TRANSAXLE, ZT-2800, TOP FAN, TANKLESS, LH (BOULEVARD)

ITEM #	QTY	PART #	DESCRIPTION
12	2	F-1492	RUE RING, 5/16
13	2	F-1521	WASHER, 1/2" CUSTOM, YZ
14	1	F-1664	HHCS, 1/2-13 X 2-1/4", YZ, GR5
15	1	F-1966	NUT, THIN, 1/2-13, NYLOC, FLANGED
16	8	F-2063	NUT, 5/16-18, NYLOC, FLANGED, YZ
17	1	F-2144	FHCS, 1/2-13 X 2-1/4", YZ, GR5
18	1	F-2147	FHCS, 3/8-16 X 1-1/2", YZ, GR5
19	4	F-2151	NUT, 3/8-16 NYLOC, FLANGED, YZ
20	1	F-2152	NUT, 1/2-13 NYLOC, FLANGED, YZ
21	4	F-2177	FHCS, 5/16-18 X 2-1/2, YZ, GR5
22	4	F-2178	FHCS, 5/16-18 X 3", YZ, GR5
23	2	F-2218	FHCS, 3/8-16 X 2-1/4", YZ, GR5
24	1	H-2907	SPRING, 5.43 X 1-1/2", TAPERED ENDS

AVENUE/BOULEVARD

SEATS, ARM RESTS,
& RELATED PARTS

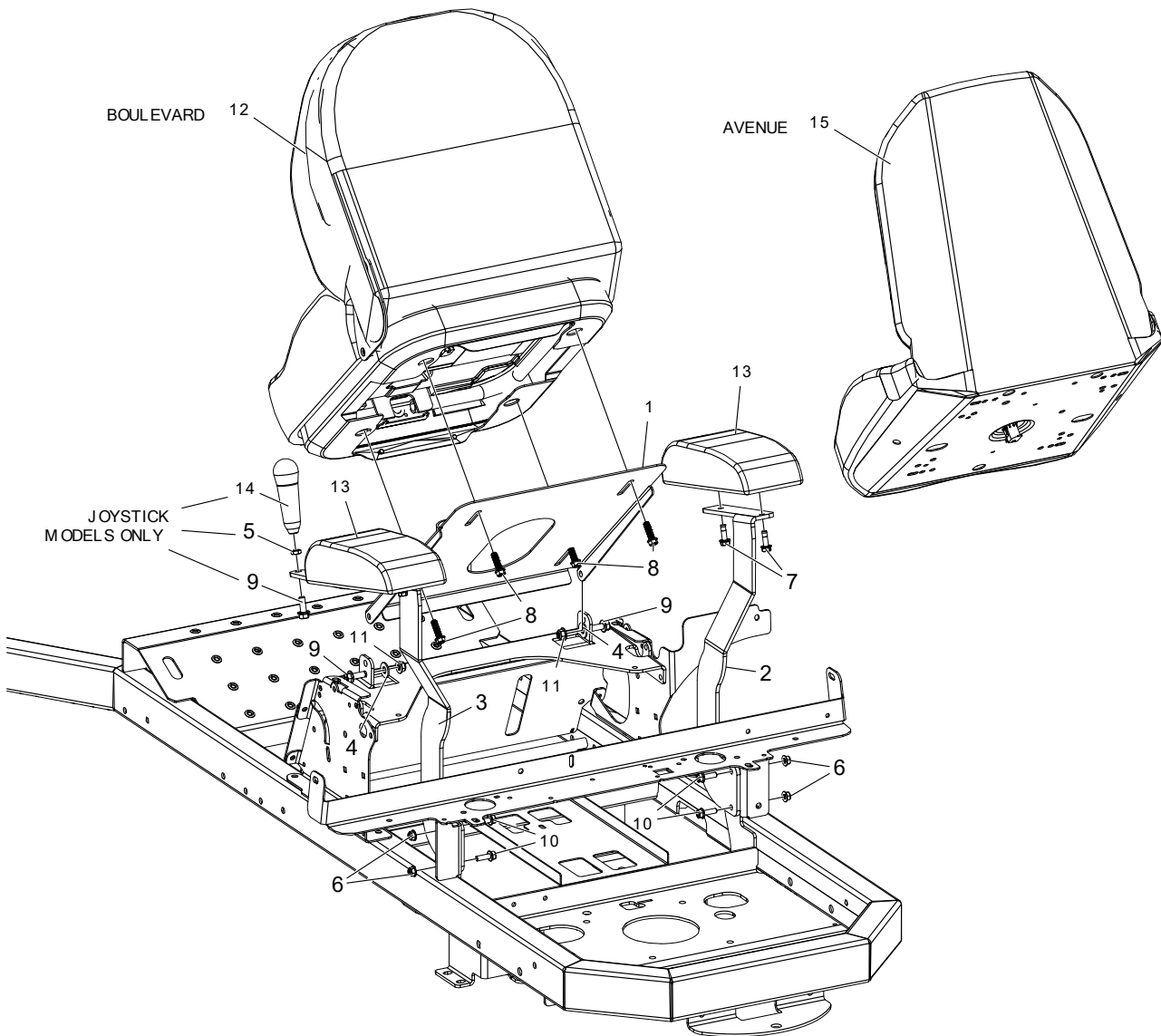

ITEM #	QTY	PART #	DESCRIPTION
1	1	714-026P	PAN, SEAT MOUNT
2	1	714-469P	ARM REST MOUNT BRACKET, RH, (FIXED)
3	1	721-147P	ARM REST MOUNT BRACKET, LH, JS, (FIXED)
-	1	721-148P	ARM REST MOUNT BRACKET, LH, TS, (FIXED)
4	2	F-1009-03	WASHER, FLAT, 3/8, YZ
5	1	F-1486	NUT, JAM, 3/8-16, YZ
6	4	F-2063	NUT, 5/16-18, NYLOC, FLANGED, YZ
7	4	F-2121	FHCS, 5/16-18 X 1", LOCK PATCH, YZ, GR5
8	4	F-2122	FHCS, 5/16-18 X 1-1/4", GR5, FULL THREAD
9	3	F-2141	FHCS, 3/8-16 X 1", YZ, GR5
10	4	F-2148	FHCS, 5/16-18 X 1", YZ, GR5
11	2	F-2151	NUT, 3/8-16 NYLOC, FLANGED, YZ
12	1	H-3207	BLVD SEAT ASSY, BLK & GRY W/ SWITCH
-	1	H-3213	SEAT BACK COVER FOR H-3207
13	2	H-2799	PAD, ARM REST
14	1	H-2764	HANDLE, JOYSTICK
15	1	H-3206	AVE SEAT ASSY, BLK & GRY, W/SWITCH
-	1	H-3212	SEAT BACK COVER FOR H-3206

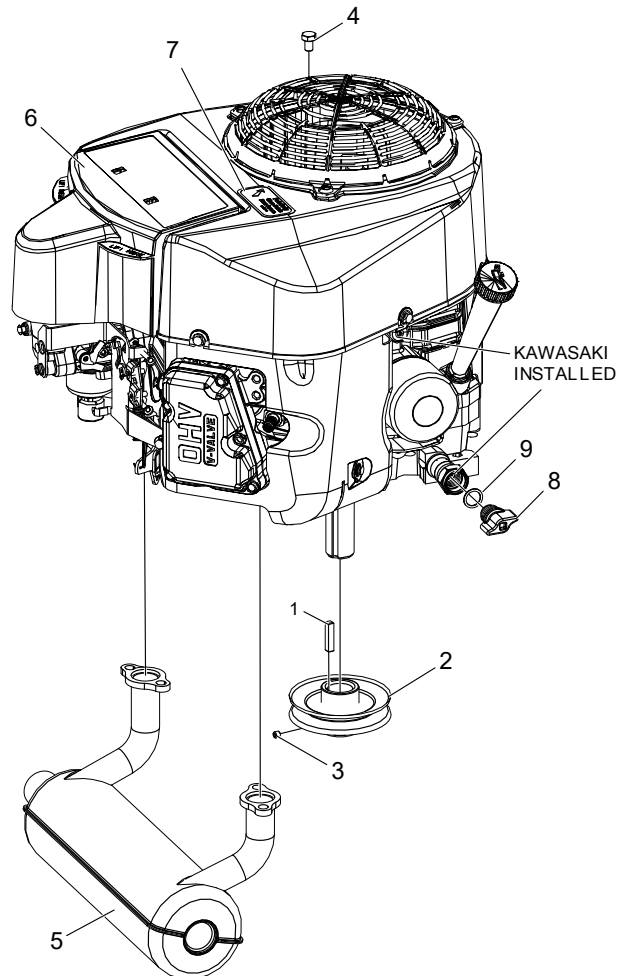

KAWASAKI

18 HP FR600V (AVENUE)
 21.5 HP FR651V (AVENUE)
 23 HP FR691V (BOULEVARD)

(USE THROTTLE CABLE H-2610 & CHOKE CABLE H-2287)

ITEM #	QTY	PART #	DESCRIPTION
1	1	621-113P	SQUARE KEY 1/4 X 1/4 X 1-1/4
2	1	D-3929	PULLEY MOTOR, O.D. 3.83" (AVENUE)
-	1	D-3935	PULLEY MOTOR, O.D. 4.639" (BOULEVARD)
3	1	F-1228	SET SCREW, SOCKET, 1/4-20 X 1/4", W/NYLOC
4	1	F-2243	HHCS, M8-1.25 X 12, YZ, GR8
5	1	H-2906	MUFFLER, COMPACT, KAWASAKI, FR600
-	1	H-3020	MUFFLER, KAWASAKI, FR651 & FR691
6	1	M-5402	ENGINE, KAWASAKI, 18HP, FR600V (AVE)
-	1	M-5442	ENGINE, KAWASAKI, 21.5HP, FR651V (AVE)
-	1	M-5443	ENGINE, KAWASAKI, 23HP, FR691V (BLVD)
7	1	P-10077-11	DECAL, "PERIODICALLY CLEAN"
8	1	H-3253	OIL PLUG, THUMB SCREW
9	1	H-3254	O-RING, OIL PLUG, THUMB SCREW

ENGINE & CLUTCH MOUNTING & RELATED PARTS

(LOOKING AT BOTTOM)

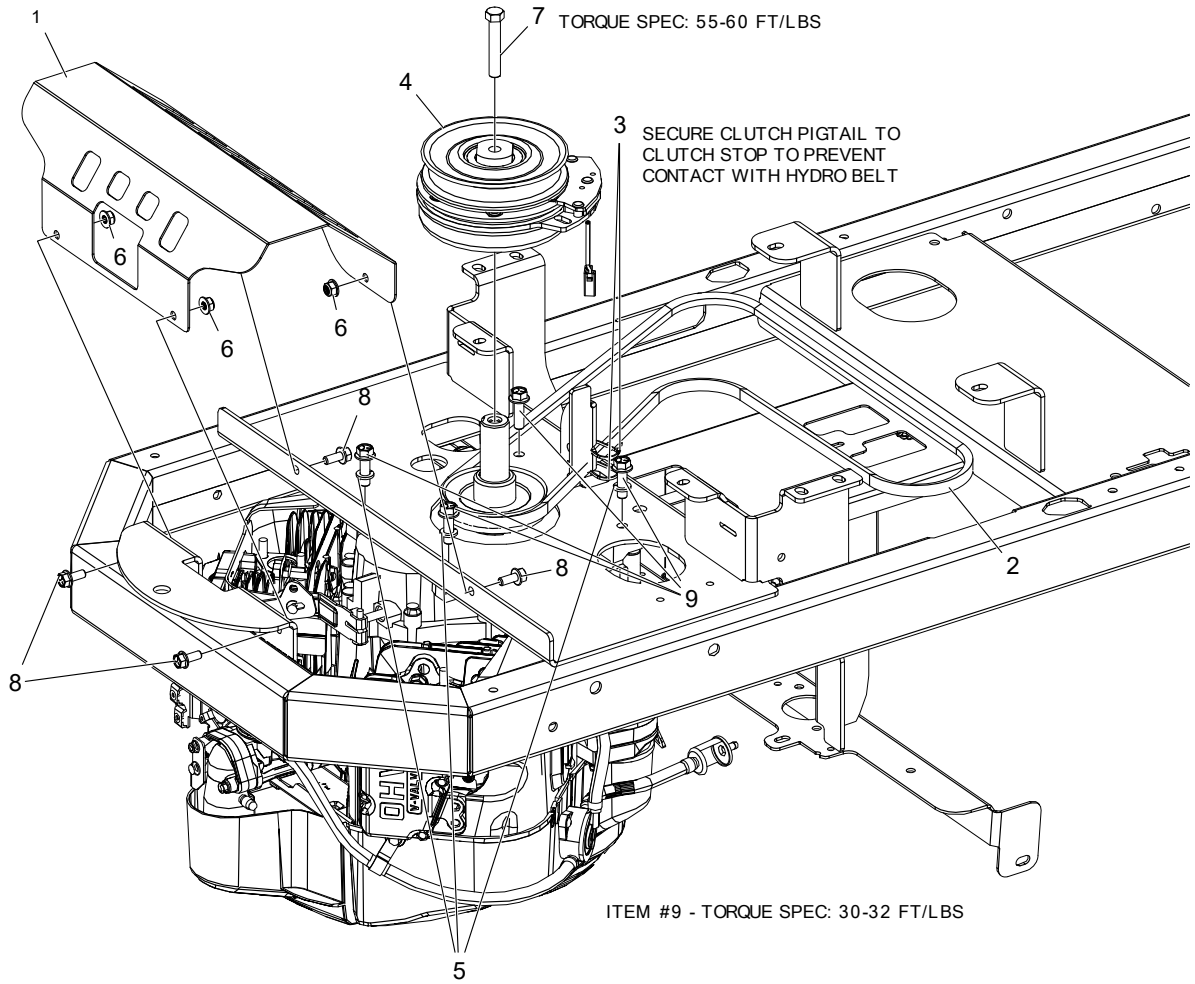

ITEM #	QTY	PART #	DESCRIPTION
1	1	714-398P	GUARD, MUFFLER
2	1	D-3769	V-BELT A-67 KEVLAR
3	2	E-5842	WIRE TIE
4	1	E-6826	MS CLUTCH, WARNER, 105 FT-LBS NOM, 1" SHAFT
5	3	F-1019-03	LOCKWASHER, HVY, 3/8, YZ
6	4	F-2063	NUT, 5/16-18, NYLOC, FLANGED, YZ
7	1	F-2113	CAPSCREW, 7/16-20 X 2-1/2", GR8, YZ
8	4	F-2120	FHCS, 5/16-18 X 3/4", YZ, GR5
9	4	F-2125	FHCS, 3/8-16 X 1-1/4", YZ, GR5

WIRE HARNESS & RELATED PARTS

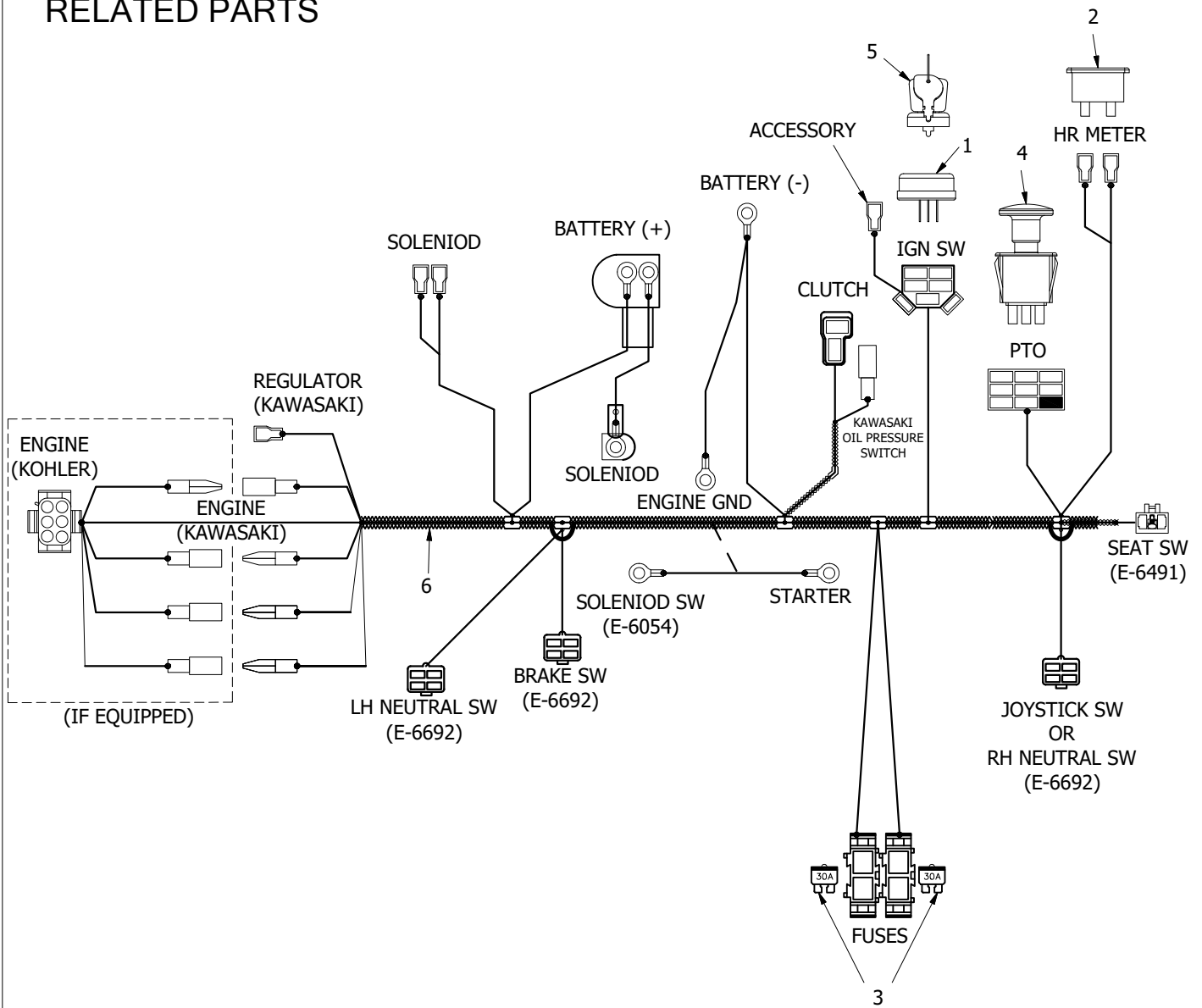

ITEM #	PART #	DESCRIPTION
1	E-6717	IGNITION SWITCH, 4 POSITION
2	E-5878	HOUR METER
3	E-6207	FUSE, #ATC-30
4	E-6403	PTO SWITCH
5	E-6718	KEY ASSEMBLY
6	E-6822	WIRE HARNESS, COMMON

WIRING SCHEMATIC

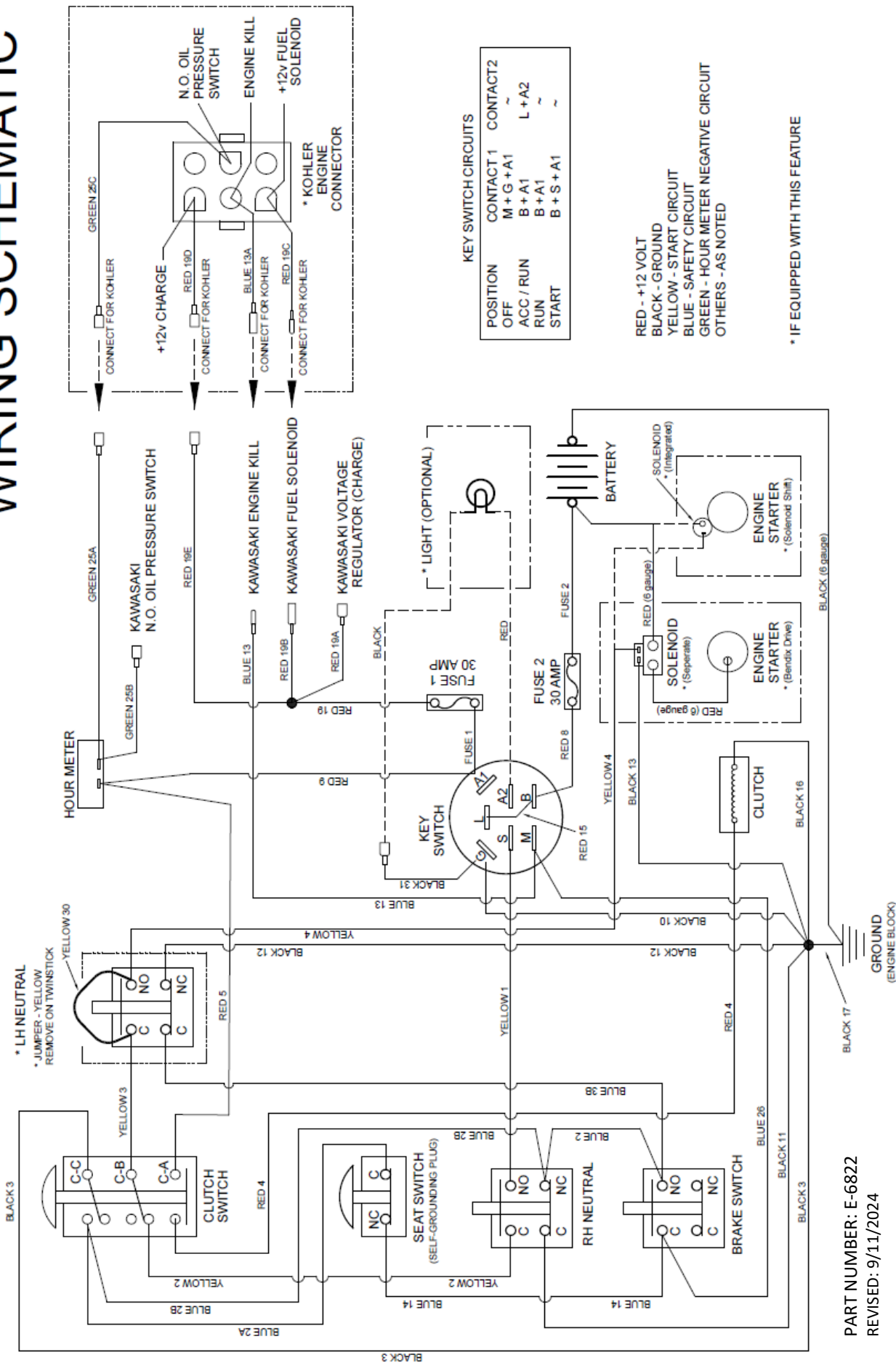

PART NUMBER: E-6822
 REVISED: 9/11/2024

SPECIFICATIONS

AVENUE

MODEL	1842KAJ-A125 / A125W	21554KAJ-A125 / A125W	1842KAT-A125 / A125W	21554KAT-A125 / A125W
Engine	18hp Kawasaki FR600 (603cc)	21.5hp Kawasaki FR651 (726cc)	18hp Kawasaki FR600 (603cc)	21.5hp Kawasaki FR651 (726cc)
Hydrostatic Transmissions	Hydro-Gear ZT-2200 w/RTN Spring			
Steering Control	Single Joystick		Twinstick Controls	
Fuel Capacity	5 Gallons			
Tires, Rear	18 x 8.5-8 Turf	18 x 9.5-8 Turf	18 x 8.5-8 Turf	18 x 9.5-8 Turf
Tires, Front	13 x 5-6 Smooth			
Turning Radius	Zero-Turn			
Ground Speed	7 MPH (infinitely variable)			
Forward	3-3/4 MPH (infinitely variable)			
Reverse	3-3/4 MPH (infinitely variable)			
Length	79"			
Height,	29" (Seat Cushion), 45" (Seat Back)			
Width, Tractor (outside rear tires)	43"	45"	43"	45"
Width, Deck (deck chute up)	43"	55"	43"	55"
(deck chute down)	54"	67"	54"	67"
Cutting Width	42"	54"	42"	54"
Blade Length	21" (2 per deck)	18 3/8" (3 per deck)	21" (2 per deck)	18 3/8" (3 per deck)
Cutting Height	1-1/2" to 4-1/2" (1/2" increments)			
Weight (actual)	595#	649#	599#	653#
Standard Features	Auto Detach Stand-Up Deck, Electric Start, Sewn Seat, Sewn Arm Rest, Cup Holder, Fixed Front End, and Hitch Plate			

BOULEVARD

MODEL	2348KAJ-B225 / B225W	2354KAJ-B225 / B225W	2360KAJ-B225 / B225W	2348KAT-B225 / B225W	2354KAT-B225 / B225W	2360KAT-B225 / B225W
Engine	23hp Kawasaki FR691 (726cc)					
Hydrostatic Transmissions	Hydro-Gear ZT-2800 w/RTN Spring					
Steering Control	Single Joystick			Twinstick Controls		
Fuel Capacity	5 Gallons					
Tires, Rear	20 x10-10 Turf	20 x12-10 Turf		20 x10-10 Turf	20 x12-10 Turf	
Tires, Front	13 x 6.5-6 Smooth					
Turning Radius	Zero-Turn					
Ground Speed	7-1/2 MPH (infinitely variable)					
Forward	4 MPH (infinitely variable)					
Reverse	4 MPH (infinitely variable)					
Length	79"					
Height,	30" (Seat Cushion), 46" (Seat Back)					
Width, Tractor (outside rear tires)	47"	49"		47"	49"	
Width, Deck (deck chute up)	50"	55"	62"	50"	55"	62"
(deck chute down)	58"	67"	74"	58"	67"	74"
Cutting Width	48"	54"	60"	48"	54"	60"
Blade Length (3 per deck)	17"	18-3/8"	21"	17"	18-3/8"	21"
Cutting Height	1 1/2" to 4 1/2" (1/2" increments)					
Weight (actual)	694#	706#	720#	699#	710#	725#
Standard Features	Auto Detach Stand-Up Deck, Hour Meter, Electric Start, Sewn Seat, Sewn Arm Rest, Cup Holder, Fixed Front End, and Hitch Plate					

Specifications subject to change without prior notice



PRODUCT MANUAL

AVENUE

A125 / A125W

BOULEVARD

B225 / B225W

Country Clipper Division

Shivers Manufacturing, Inc.

613 W. English St.

Corydon, IA 50060-0467

Ph. 641-872-2544

Fax. 641-872-1593

P-13704 (Rev C)