

Repair Parts

C C O U N T R Y
CLIPPER
Z E R O T U R N M O W E R

BOSS^{XL} 9015 / 9015W

SERIAL RANGE: 24266001 - _____

COUNTRY CLIPPER
BOSS XL - 9015 / 9015W
SERIAL RANGE 24266001 - _____
ZERO TURN RADIUS MOWER
TABLE OF CONTENTS

SECTION 1 – MOWER DECKS AND RELATED PARTS

1. 60" DECK ASSEMBLY
2. 72" DECK ASSEMBLY
3. DISCHARGE CHUTE ASSEMBLY
4. DECK SPINDLE ASSEMBLY
5. DECK IDLER
6. DECK LIFT ASSEMBLY & RELATED PARTS
7. DECK LIFT ASSEMBLY & RELATED PARTS (CON'T)
8. CUT HEIGHT ASSEMBLY & RELATED PARTS
9. JACK ASSEMBLY

SECTION 2 – TRACTOR FRAME AND RELATED PARTS

10. PIVOTING FRONT AXLE
11. FRONT STEP & FOOT PAN
12. FRONT PANEL ASSEMBLY
13. RH FENDER & RELATED PARTS
14. LH FENDER & RELATED PARTS
15. ENGINE GUARD
16. ROPS
17. SEAT
18. SEAT BASE

SECTION 3 – TRACTOR DRIVE AND RELATED PARTS

19. FUEL TANK ASSEMBLY
20. JOYSTICK CONTROL & RELATED PARTS
21. JOYSTICK ASSEMBLY
22. JOYSTICK ASSEMBLY MOUNTING & RELATED PARTS
23. TWIN LEVER CONTROL & RELATED PARTS
24. TWIN LEVER ASSEMBLY
25. CONTROL PANEL – KAWASAKI
26. BRAKE
27. TRANSMISSION ASSEMBLY & RELATED PARTS
28. HYDRO MOUNT
29. HYDRO IDLER
30. DOUBLE IDLER
31. TIRES
32. BATTERY
33. ENGINES
34. ENGINE & CLUTCH MOUNTING & RELATED PARTS
35. WIRE HARNESS & RELATED PARTS (CARBURETED)
36. WIRE HARNESS SCHEMATIC (CARBURETED)

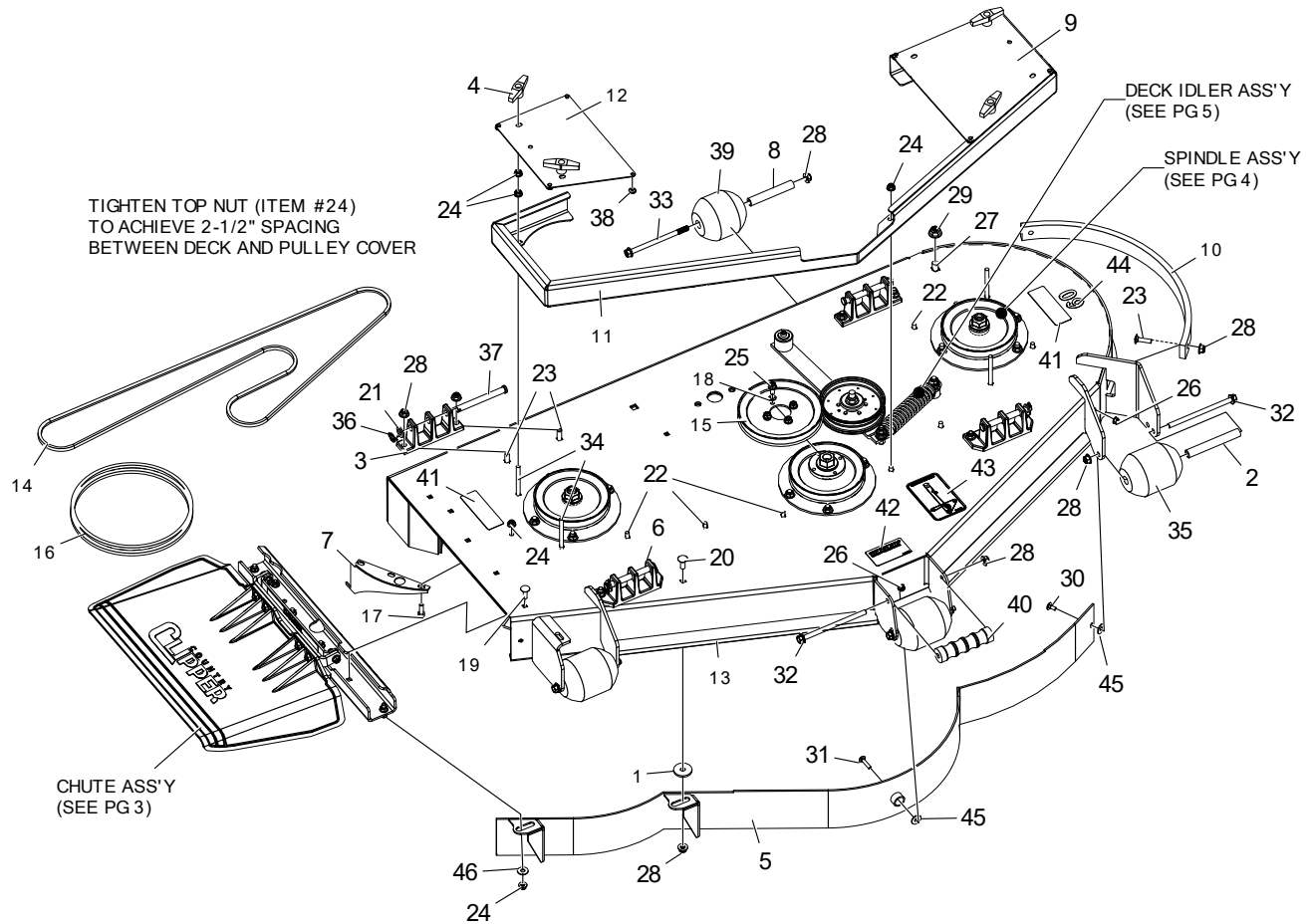

Item #	Qty	Part #	Description
1	1	609-034P	SPINDLE SPACER WASHER
2	3	609-183P	BUSHING
3	2	643-016W	DECK HANGER, NARROW BASE
4	4	643-072A	T-HANDLE ASSY W/ NUT
5	1	643-104W	60" DUST BAFFLE WELDMENT
6	2	651-009W	DECK HANGER, WIDE BASE
7	1	686-006W	SPLITTER WELDMENT
8	2	714-133P	BUSHING, ROLLER BRACKET
9	1	730-032A	PULLEY COVER, TRIM
10	1	730-015P	PLASTIC WEAR STRIP
11	1	730-020P	TOP STIFFENER, 60
12	1	730-033A	PULLEY COVER, DISCHARGE
13	1	730-026A	60" DECK W/ DECALS
14	1	D-3796	V-BELT B-124 DAYCO #7-9537, DECK
15	1	D-4073	PULLEY, CENTER, 60
16	1	D-4075	V-BELT, B-109, KEVLAR, ENGINE TO DECK
17	1	F-1015-15	HHCS, 5/16-18 X 1", YZ, GR5
18	4	F-1019-02	LOCKWASHER, HVY, 5/16, YZ
19	1	F-1106	BOLT, CARRIAGE, 5/16-18 X 1-1/4, YZ, GR5
20	1	F-1274	CARRIAGE BOLT, 3/8 X 1", YZ, GR5
21	4	F-1521	WASHER, 1/2" CUSTOM, YZ
22	7	F-1671	CARRIAGE BOLT, 5/16-18 X 3/4", YZ, GR5
23	10	F-1672	BOLT, CARRIAGE, 3/8-16 X 1-1/4", YZ, GR5

Item #	Qty	Part #	Description
24	17	F-2063	NUT, 5/16-18, NYLOC, FLANGED, YZ
25	4	F-2120	FHCS, 5/16-18 X 3/4", YZ, GR5
26	2	F-2132	NUT, 1/4-20 NYLOC, FLANGED, YZ
27	1	F-2146	CARRIAGE BOLT, 1/2-13 X 1", YZ, GR5
28	17	F-2151	NUT, 3/8-16 NYLOC, FLANGED, YZ
29	1	F-2152	NUT, 1/2-13 NYLOC, FLANGED, YZ
30	1	F-2155	BOLT, CARRIAGE, 1/4-20 X 5/8", YZ, GR5
31	1	F-2157	BOLT, CARRIAGE, 1/4-20 X 1-1/4", YZ, GR5
32	4	F-2161	FHCS, 3/18-16 X 6" YZ, GR5
33	2	F-2222	FHCS, 3/8-16 X 5-1/2", YZ, GR5
34	4	F-2298	CARRIAGE BOLT, 5/16-18 X 3-1/2"
35	3	H-1948	ROLLER, 3-3/4 DIA
36	4	H-2239	1/2" RUE RING
37	4	H-2240	1/2" X 4-1/2" CLEVIS PIN
38	8	H-3188	RUBBER BUMPER
39	2	H-2768	ROLLER, 3-3/4 DIA. X 4"
40	1	H-2787	GRIP, DECK HANDLE
41	2	P-13749	DECAL, DECK SAFETY
42	1	P-11413	DECAL, HOIST POINT
43	1	P-11935	DECAL, BELT ROUTING
44	1	P-11952	DECAL, DECK SIZE, 60
45	2	F-1009-01	FLAT WASHER, 1/4", YZ
46	1	F-1009-02	WASHER, FLAT

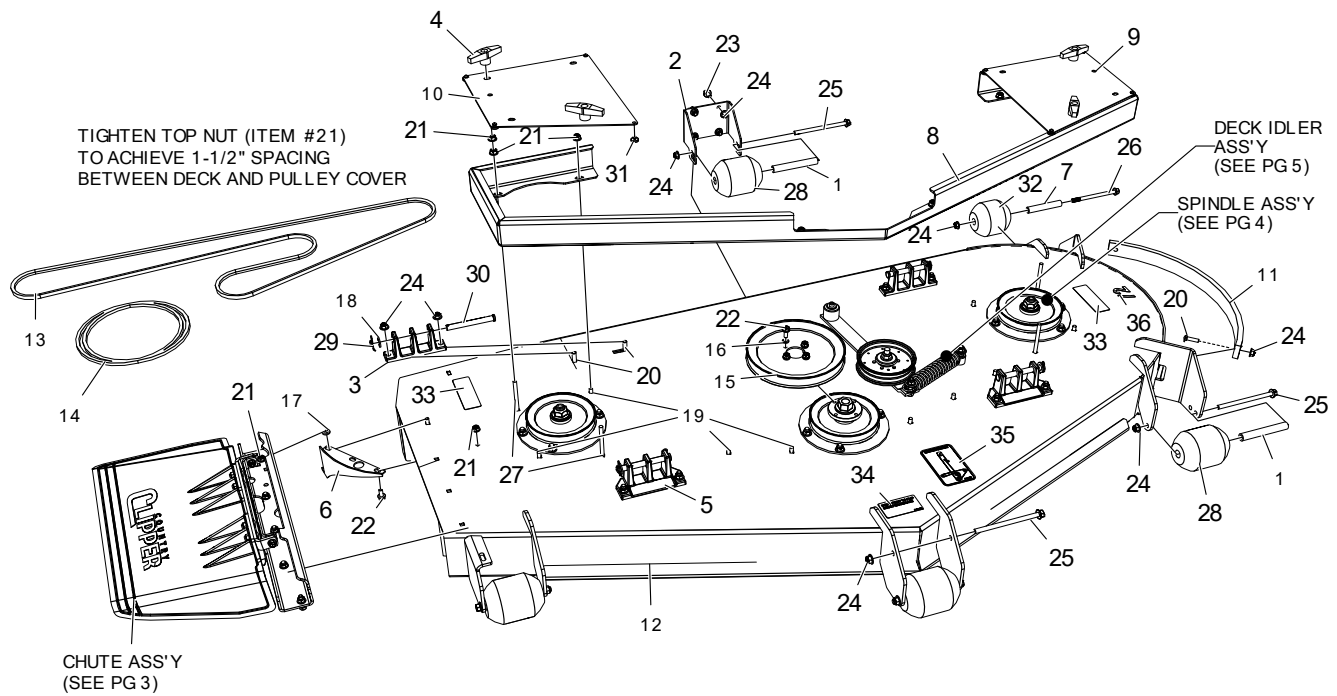

Item #	Qty	Part #	Description
1	4	609-183P	BUSHING
2	1	637-006P	BRACKET, REAR ROLLER
3	2	643-016W	DECK HANGER, NARROW BASE
4	4	643-072A	T-HANDLE ASSY W/ NUT
5	2	651-009W	DECK HANGER, WIDE BASE
6	1	686-006W	SPLITTER WELDMENT
7	2	714-133P	BUSHING, ROLLER BRACKET
8	1	730-002P	TOP STIFFENER, 72
9	1	730-032A	PULLEY COVER, TRIM
10	1	730-034A	PULLEY COVER, DISCHARGE
11	1	730-015P	PLASTIC WEAR STRIP
12	1	730-027A	72" DECK W/ DECALS
13	1	D-3797	V-BELT B-142 DAYCO #7-9535, DECK
14	1	D-3902	V- BELT, B-116", ENGINE TO DECK
15	1	D-4072	PULLEY, CENTER, 72
16	4	F-1019-02	LOCK WASHER, HVY, 5/16, YZ
17	1	F-1019-03	LOCK WASHER, HVY, 3/8, YZ
18	4	F-1521	WASHER, 1/2" CUSTOM, YZ

Item #	Qty	Part #	Description
19	10	F-1671	CARRIAGE BOLT, 5/16-18 X 3/4", YZ, GR5
20	10	F-1672	BOLT, CARRIAGE, 3/8-16 X 1-1/4", YZ, GR5
21	16	F-2063	NUT, 5/16-18, NYLOC, FLANGED, YZ
22	5	F-2120	FHCS, 5/16-18 X 3/4", YZ, GR5
23	4	F-2124	FHCS, 3/8-16 X 3/4", YZ, GR5
24	21	F-2151	NUT, 3/8-16 NYLOC, FLANGED, YZ
25	5	F-2161	FHCS, 3/18-16 X 6" YZ, GR5
26	2	F-2222	FHCS, 3/8-16 X 5-1/2", YZ, GR5
27	4	F-2298	CARRIAGE BOLT, 5/16-18 X 3-1/2"
28	4	H-1948	ROLLER, 3-3/4 DIA
29	4	H-2239	1/2" RUE RING
30	4	H-2240	1/2" X 4-1/2" CLEVIS PIN
31	8	H-3188	RUBBER BUMPER
32	2	H-2768	ROLLER, 3-3/4 DIA. X 4"
33	2	P-13749	DECAL, DECK SAFETY
34	1	P-11413	DECAL, HOIST POINT
35	1	P-11935	DECAL, BELT ROUTING
36	1	P-11953	DECAL, DECK SIZE, 72

DISCHARGE CHUTE ASSEMBLY & RELATED PARTS

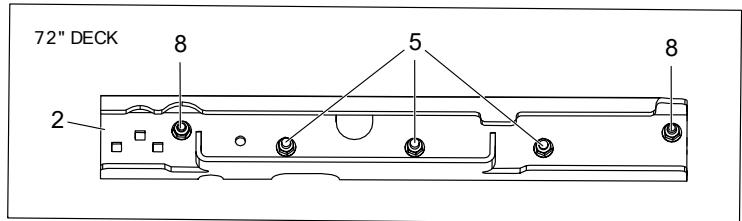
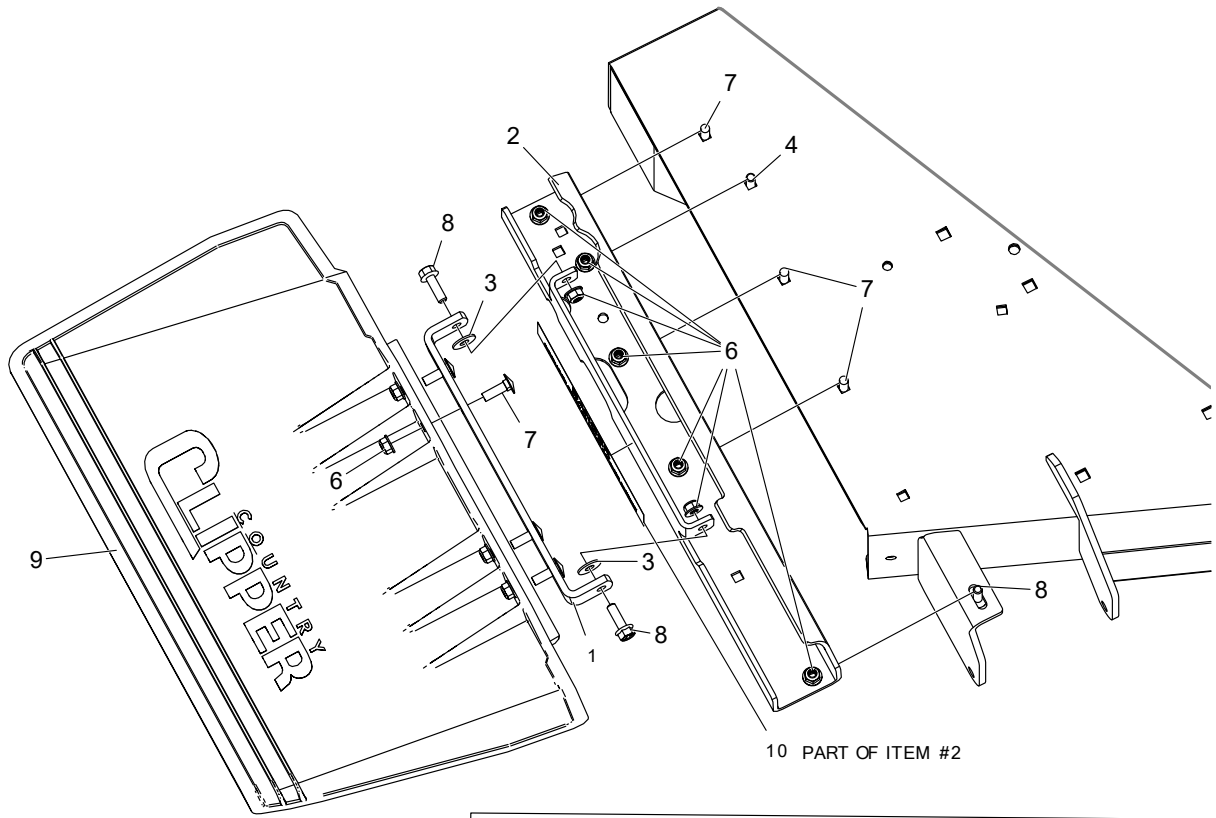

Item #	Qty	Part #	Description
1	1	643-110P	CHUTE HINGE
2	1	643-135A	OUTLET STIFFENER W/DECALS, SMALL
3	2	F-1009-02	WASHER, FLAT
4	1	F-1015-15	HHCS, 5/16-18 X 1", YZ, GR5
5	3	F-1671	BOLT, CARRIAGE, 5/16-18 X 3/4", YZ, GR5
6	11	F-2063	NUT, 5/16-18, NYLOC, FLANGED, YZ
7	7	F-2066	BOLT, CARRIAGE, 5/16-18 X 1", YZ, GR5
8	4	F-2148	FHCS, 5/16-18 X 1", YZ, GR5
9	1	H-2723	CHUTE
10	1	P-12496	DECAL, CHUTE MISSING

DECK SPINDLE ASSEMBLY
{629JY-001A}

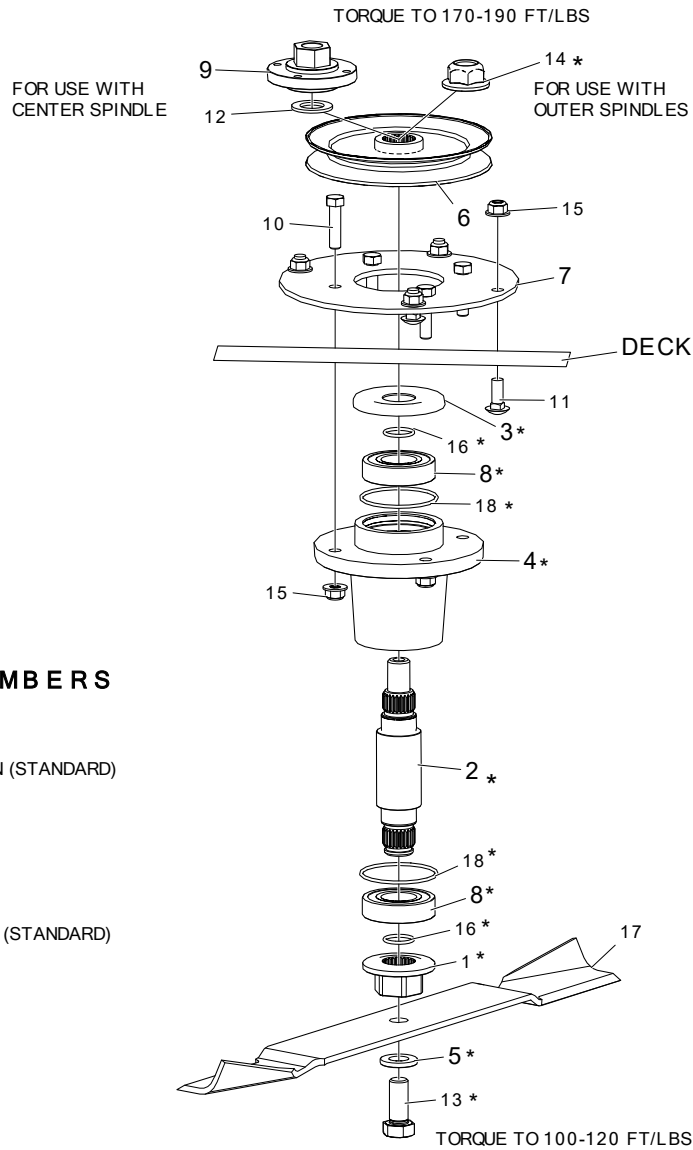

BLADE PART NUMBERS

60" DECK

- H-2886 HIGH LIFT W/ FUSION (STANDARD)
- H-2885 HIGH LIFT
- H-2661 LOW LIFT
- H-2667 GATOR

72" DECK

- H-2887 HIGH LIFT W/ FUSION (STANDARD)
- H-2656 HIGH LIFT
- H-2662 LOW LIFT
- H-2877 GATOR

Item #	Qty	Part #	Description
1	1	609-288P	DRIVER, BLADE, FRICTION, SPL
2	1	609-289P	SHAFT, SPINDLE, HD
3	1	609-292P	CAP, BEARING
4	1	609-302P	HSG, SPINDLE, HD
5	1	660-099P	WASHER, BLADE, 5/8
6	1	668-042P	PULLEY, 5.676PD, "B", SPLINE
7	1	730-006P	WASHER PLATE, REINFORCEMENT
8	2	D-3867	BRG, BALL, 6206, F-SEALS
9	1	D-4071	HUB, PULLEY, TOP, BOLTED

Item #	Qty	Part #	Description
10	4	F-1015-27	HHCS, 3/8-16 X 1-1/2", YZ, GR5
11	4	F-1274	CARRIAGE BOLT, 3/8 X 1", YZ, GR5
12	1	F-1510	WASHER, FLAT, 3/4"
13	1	F-2073	HHCS, 5/8-11 X 1-1/2", GR8, YZ
14	1	F-2078	NUT, 3/4-16, TOP LOCK, GR-GT, YZ
15	8	F-2151	NUT, 3/8-16 NYLOC, FLANGED, YZ
16	2	H-2639	O-RING, -117, 70 DURO
17	1	-----	BLADE, SEE LISTING ABOVE
18	2	H-3178	O-RING, SPINDLE, HSG

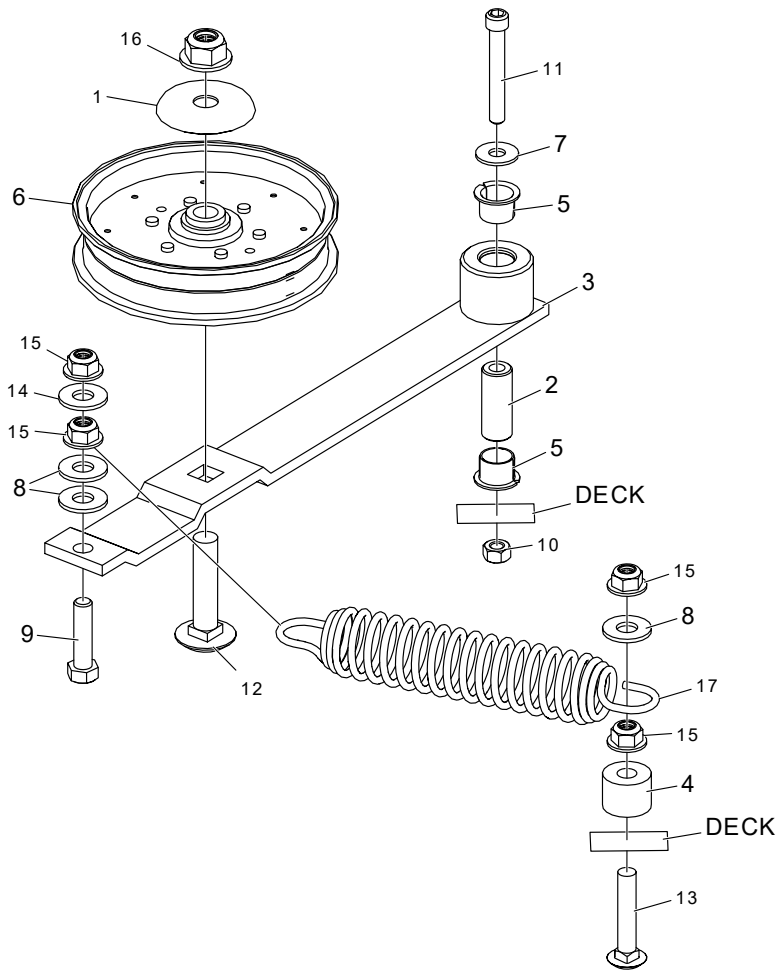

Item #	Qty	Part #	Description
1	1	620-201P	WASHER, BEARING CAP
2	1	621-103P	MOUNTING PIN
3	1	643-078W	SINGLE IDLER ARM LONG WLDT
4	1	668-045P	SPACER, SPRING MTG
5	2	D-3730	BUSHING, DU 5/8 DIA X 1/2 LG
6	1	D-3904	PULLEY, FLAT IDLER, 5"
7	1	F-1009-02	WASHER, FLAT
8	3	F-1009-03	WASHER, FLAT, 3/8, YZ
9	1	F-1015-27	HHCS, 3/8-16 X 1-1/2", YZ, GR5
10	1	F-1125	NUT, CENTERLOCK, 5/16-18, YZ, GR5
11	1	F-1800	SHCS, 5/16-18 X 2-1/4", YZ, GR5
12	1	F-1822	BOLT, CARRIAGE, 1/2-13 X 2-1/4", YZ, GR5
13	1	F-1976	BOLT, CARRIAGE, 3/8-16 X 2", YZ, GR5
14	1	F-2083	WASHER, FENDER, 3/8"
15	4	F-2151	NUT, 3/8-16 NYLOC, FLANGED, YZ
16	1	F-2152	NUT, 1/2-13 NYLOC, FLANGED, YZ
17	1	H-2619	SPRING, 5 X 1-1/2, TAPERED ENDS

DECK LIFT ASSEMBLY
& RELATED PARTS

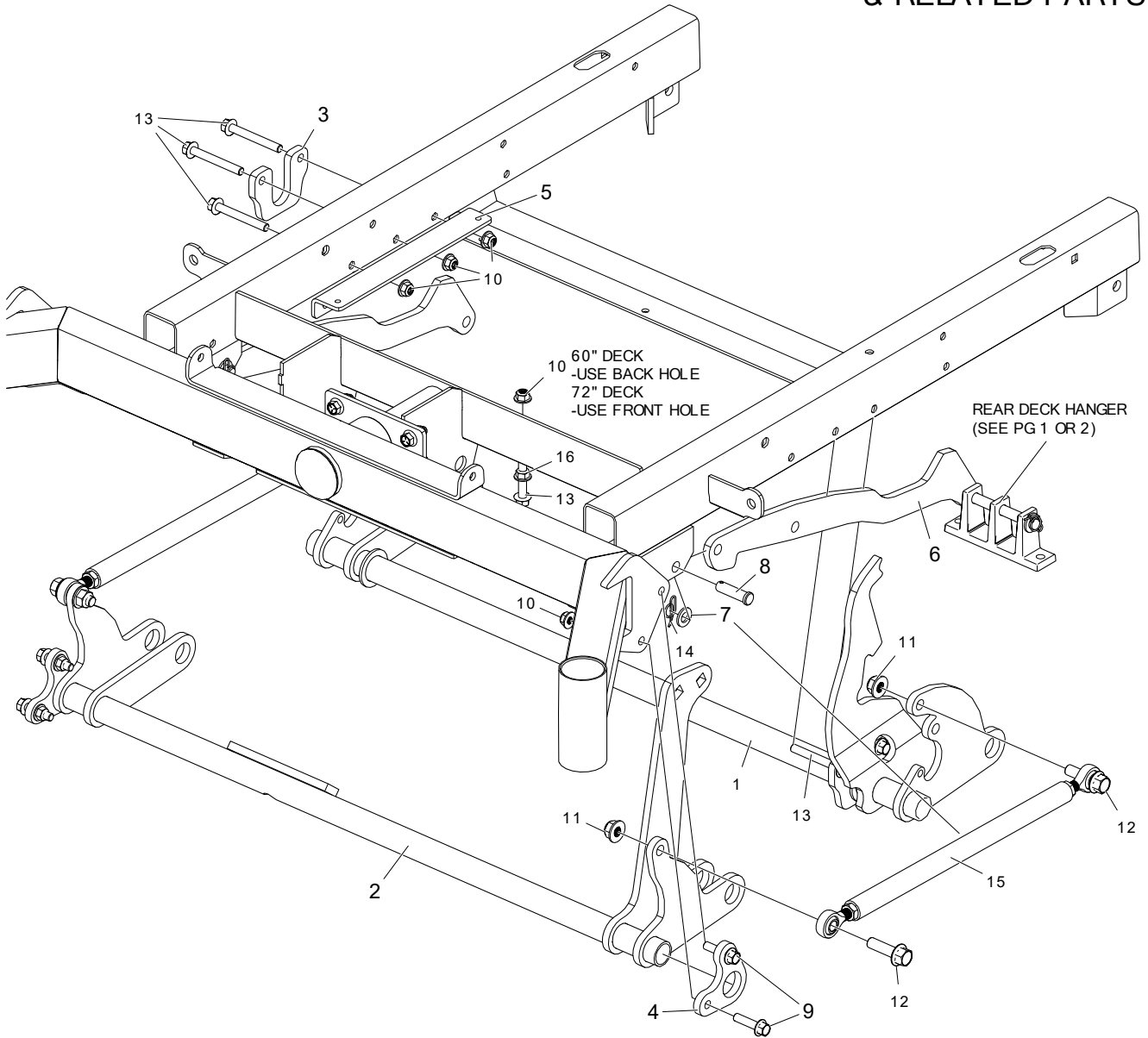

Item #	Qty	Part #	Description
1	1	724-021W	WLDT, DECK LIFT, REAR
2	1	724-026W	WLDT, DECK LIFT, FRONT
3	2	724-032P	DECK PIVOT MOUNT PLATE
4	2	724-033P	DECK SUSPENSION FRONT PLATE
5	2	724-045P	FLOOR PAN SUPPORT ANGLE
6	2	724-117P	DRAG BAR
7	2	F-1521	WASHER, 1/2" CUSTOM, YZ
8	2	F-1896	CLEVIS PIN, 1/2 X 1-3/4", YZ
9	4	F-2147	FHCS, 3/8-16 X 1-1/2", YZ, GR5
10	10	F-2151	NUT, 3/8-16 NYLOC, FLANGED, YZ
11	4	F-2152	NUT, 1/2-13 NYLOC, FLANGED, YZ
12	4	F-2154	FHCS, 1/2-13 x 1-3/4", YZ, GR5
13	6	F-2180	FHCS, 3/8-16 x 3", YZ, GR5
14	2	H-2239	1/2" RUE RING
15	2	H-3153	DECK LIFT LINKAGE
16	1	F-1486	JAM NUT, 3/8-16

DECK LIFT ASSEMBLY
& RELATED PARTS (CONT')

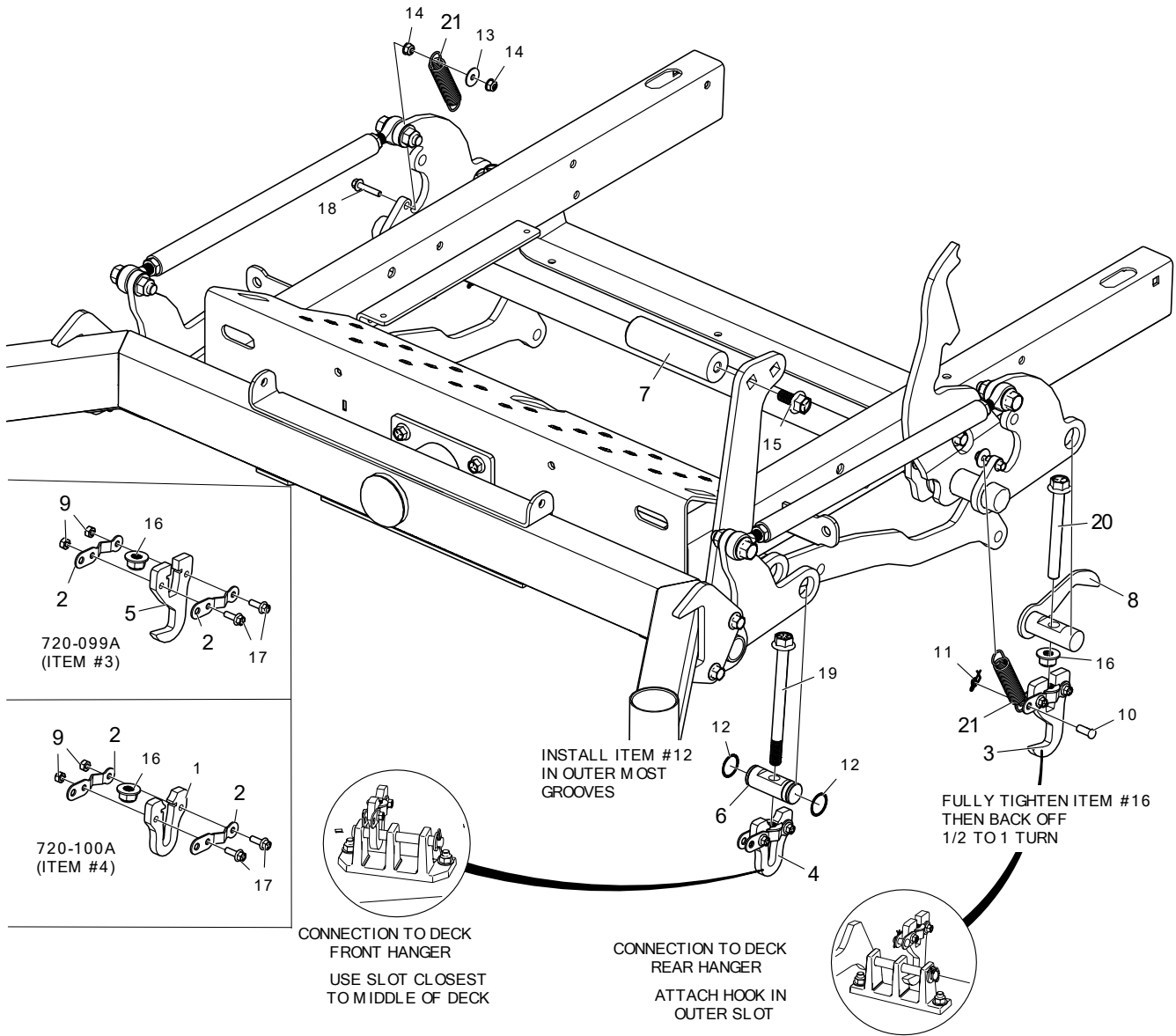

Item #	Qty	Part #	Description
1	1	720-097P	DECK HANGER, FRONT
2	4	720-098P	NUT RETAINER
3	1	720-099A	ASS'Y, DECK HANGER, REAR
4	1	720-100A	ASS'Y, DECK HANGER, FRONT
5	1	720-115P	HOOK, REAR DECK
6	2	724-052P	HANGER PIN, FRONT
7	1	724-084P	FOOT PEG
8	1	724-091W	HANGER PIN WLDT, REAR LH
-	1	724-092W	HANGER PIN WLDT, REAR RH
9	4	F-1158	NUT, CENTERLOCK, 1/4-20, YZ, GR5
10	2	F-1443	CLEVIS PIN, 5/16 X 7/8"

Item #	Qty	Part #	Description
11	2	F-1492	RUE RING, 5/16
12	4	F-1998	SPIROL RING 1"
13	2	F-2097	WASHER, FENDER, 0.25 X 0.875
14	4	F-2132	NUT, 1/4-20 NYLOC, FLANGED, YZ
15	1	F-2143	FHCS, 1/2-13 X 1", YZ, GR5
16	4	F-2152	NUT, 1/2-13 NYLOC, FLANGED, YZ
17	4	F-2162	FHCS, 1/4-20 X 3/4", YZ, GR5
18	2	F-2182	FHCS, 1/4-20 X 1-1/4", YZ, GR5
19	2	F-2301	FHCS, 1/2-13 X 5-1/2", YZ, GR5
20	2	F-2302	FHCS 1/2-13 X 4", GR5, YZ, FULL THREAD
21	2	H-1635	SPRING, EXT, 3/4" OD X 4" OAL

CUT HEIGHT ASSEMBLY & RELATED PARTS

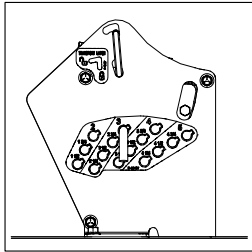

INSIDE VIEW OF CUT HEIGHT SUB-ASSEMBLY, SHOWING DECALS

CUT HEIGHT SUB-ASSEMBLY (SEE DETAIL)

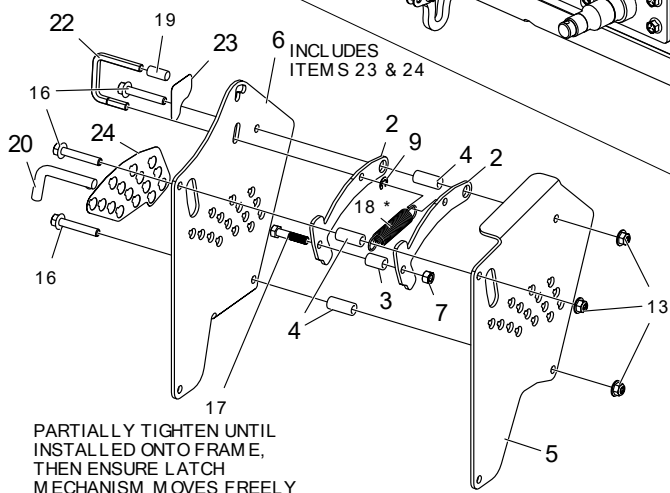
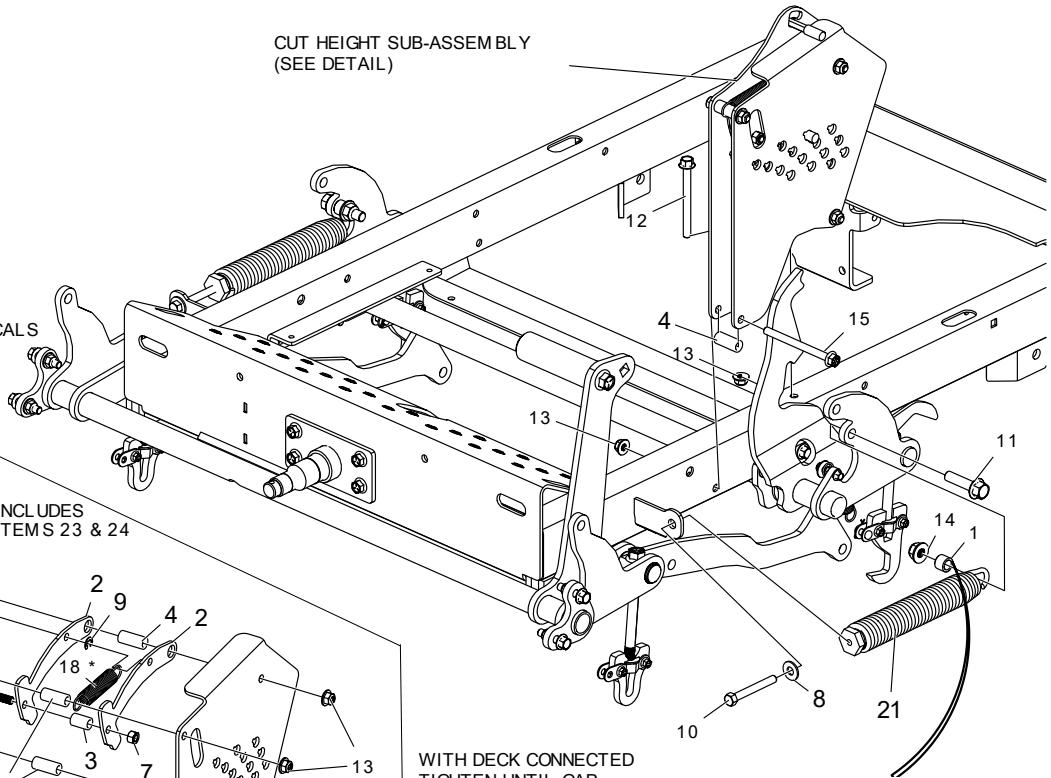

PARTIALLY TIGHTEN UNTIL INSTALLED ONTO FRAME, THEN ENSURE LATCH MECHANISM MOVES FREELY

*ATTACH SPRING TO HANDLE (H-3120) FIRST THEN TO SPACER (724-080P)

CUT HEIGHT SUB-ASSEMBLY

WITH DECK CONNECTED TIGHTEN UNTIL GAP BETWEEN TAB ON FRAME AND SPRING IS APPROXIMATELY
0.75" - 60" DECKS
0.50" - 72" DECKS

HOOK SPRING WITH OPENING FACING DOWN - LEFT SIDE FACING UP - RIGHT SIDE

Item #	Qty	Part #	Description
1	2	720-010P	CLAMP EXTENSION
2	2	724-042P	CATCH PLATE
3	1	724-079P	SPACER, CATCH PLATE
4	4	724-080P	SPACER, CUT HEIGHT PLATE
5	1	724-095P	PLATE, CUT HEIGHT, OUTER
6	1	629-972A	PLATE, CUT HEIGHT, INNER W/ DECALS
7	1	F-1005-03	NUT, 3/8-16, CENTERLOCK, YZ, GR5
8	2	F-1009-03	WASHER, FLAT, 3/8, YZ
9	1	F-1080	SNAP RING
10	2	F-1329	SCREW, 3/8-16 X 3 GR5 FULL THREADED
11	2	F-2154	FHCS, 1/2-13 X 1-3/4", YZ, GR5
12	1	F-2142	FHCS, 3/8-16 X 4", YZ, GR5

Item #	Qty	Part #	Description
13	5	F-2151	NUT, 3/8-16 NYLOC, FLANGED, YZ
14	2	F-2152	NUT, 1/2-13 NYLOC, FLANGED, YZ
15	1	F-2160	FHCS, 3/8-16 X 4-1/2", YZ, GR5
16	3	F-2218	FHCS, 3/8-16 X 2-1/4", YZ, GR5
17	1	F-2260	HHCS, 3/8-16 X 1-3/4", YZ, GR8
18	1	H-1635	SPRING, EXT, 3/4" OD X 4" OAL
19	1	H-2327	3/8 DIA X 1" LONG END CAP
20	1	H-3013	DECK HEIGHT PIN
21	2	H-3117	EXTENSION SPRING W/THREADED PLUG
22	1	H-3120	TRANSPORT LATCH RELEASE HANDLE
23	1	P-13437	DECAL, TRANSPORT LATCH
24	1	P-13477	DECAL, CUT HEIGHT

STANDARD EQUIPMENT
ON 72" MODELS ONLY

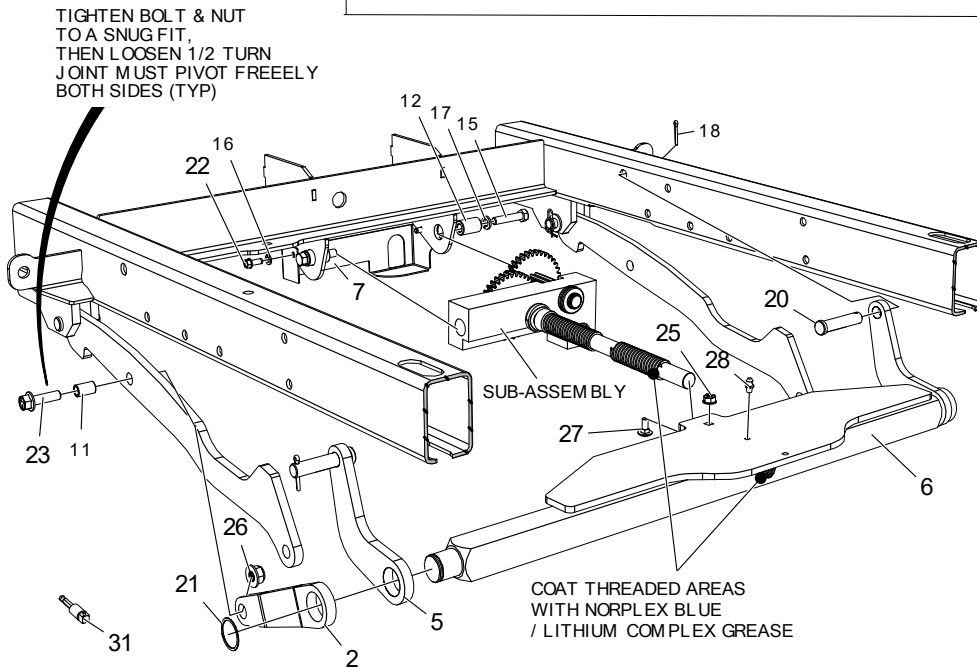
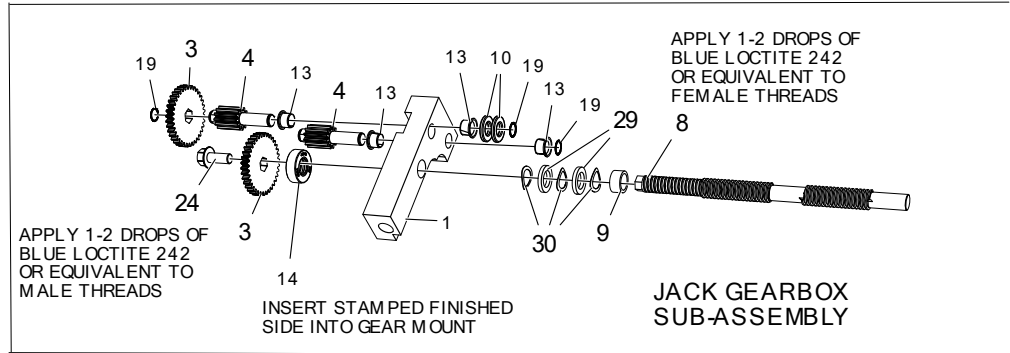

Item #	Qty	Part #	Description
1	1	629-936P	JACK GEAR MOUNT
2	2	629-941P	JACK SCISSOR ARM - OFFSET
3	2	629-946P	SPUR GEAR, 36 TOOTH
4	2	629-947P	GEAR, PINION
5	2	629-949P	JACK SCISSOR ARM, CURVED
6	1	629-991W	JACK CROSS SHAFT WLDT.
7	1	629-959P	JACK GEAR SHIELD
8	1	629-1006P	JACK SHAFT
9	1	629-1007P	SPACER
10	2	660-099P	WASHER, BLADE, 5/8
11	2	707-073P	STAND-OFF, LINKAGE MOUNT
12	2	721-068P	SPACER, 1.135 LONG
13	4	D-3730	BUSHING, DU 5/8 DIA X 1/2 LG
14	1	D-4022	BEARING, THRUST
15	2	F-1015-28	HHCS, 3/8-16 X 1-3/4", YZ, GR5
16	2	F-1019-01	WASHER, LOCK, 1/4, YZ

Item #	Qty	Part #	Description
17	2	F-1019-03	LOCKWASHER, HVY, 3/8, YZ
18	2	F-1491	COTTER PIN, 1/8 X 1
19	3	F-1739	5/8 SPIRAL RETAINING RING
20	2	F-1897	PIN, CLEVIS 1/2 X 2-1/4"LG Y-D
21	2	F-1998	SPIROL RING 1"
22	2	F-2030	1/4 X 5/8", SELF-TAPPING HEX SCREW
23	2	F-2125	FHCS, 3/8-16 X 1-1/4", YZ, GR5
24	1	F-2127	FHCS, 1/2-13 X 1-1/4, YZ, GR5
25	1	F-2132	NUT, FLANGED, 1/4-20, W/NYLOC, GR5, PLATED
26	2	F-2151	NUT, 3/8-16 NYLOC, FLANGED, YZ
27	1	F-2155	BOLT, CARRIAGE, 1/4-20 X 5/8", GR5
28	1	H-1056	1/4" GREASE FITTING
29	2	H-3177	WASHER, OVERSIZED
30	2	H-3179	CURVED DISC SPRING
31	1	T-10038	3/8 SQUARE DRIVE, SHANK ADAPTER

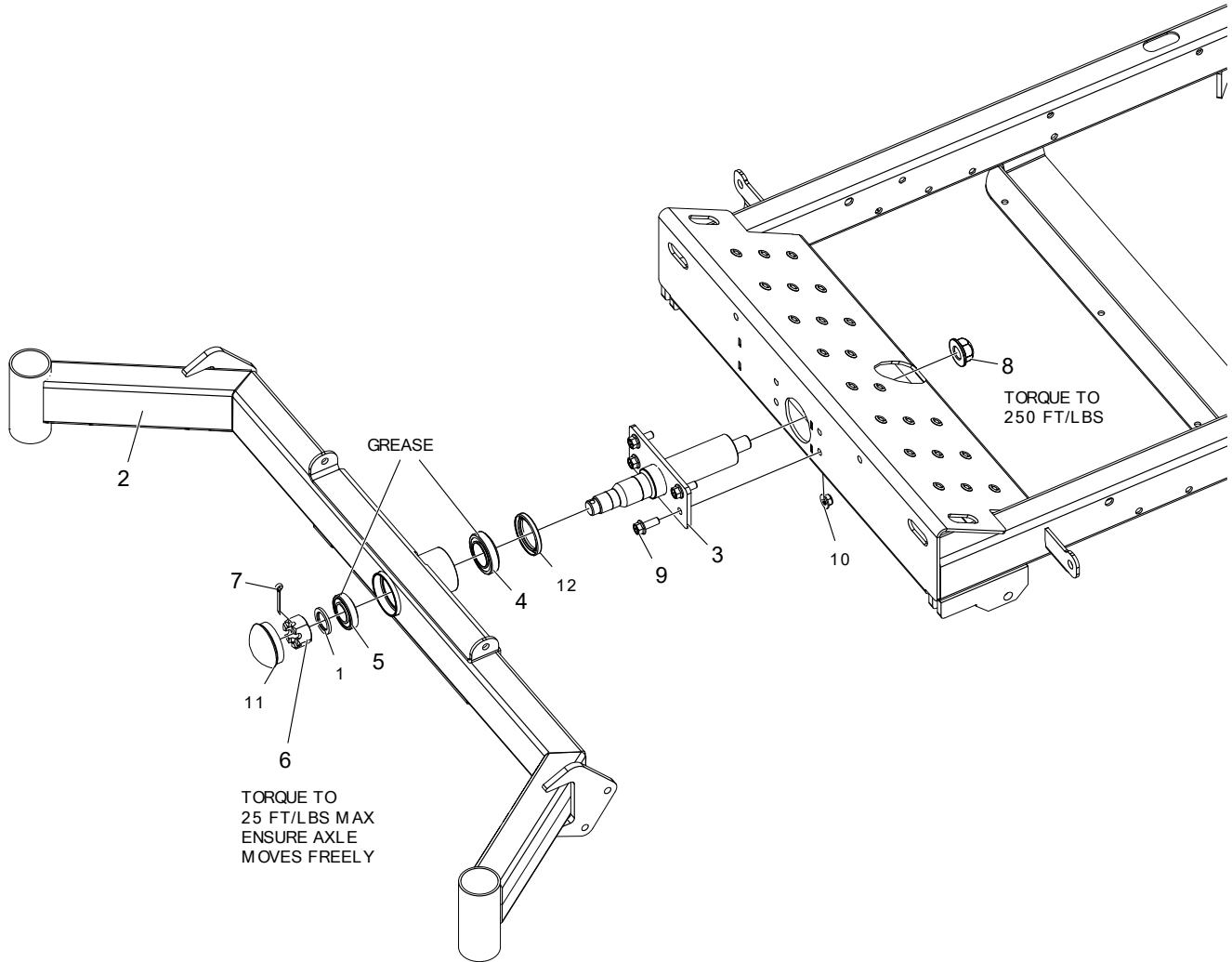

Item #	Qty	Part #	Description
1	1	606-303P	WASHER, 10GA GALVANIZED
2	1	724-170W	WLDT, FRONT AXLE
-	1	730-025W	WLDT, FRONT AXLE, 72
3	1	724-056W	WLDT, PIVOT SHAFT
4	1	D-3825-01	TRB, BEARING CONE
5	1	D-2018-01	BEARING CONE
6	1	F-1724	NUT, HEX, SLOTTED, 1-14, YZ
7	1	F-1728	COTTER PIN, 3/16 X 2", YZ
8	1	F-2078	NUT, 3/4-16, TOP LOCK, GR-GT, YZ
9	4	F-2141	FHCS, 3/8-16 X 1", YZ, GR5
10	4	F-2151	NUT, 3/8-16 NYLOC, FLANGED, YZ
11	1	H-1924	GREASE CAP PLATED
12	1	H-2812	SEAL, SHAFT, 1.75, 2.38, 0.313

PARTS MARKED ** STANDARD ON 72" DECK MODELS ONLY

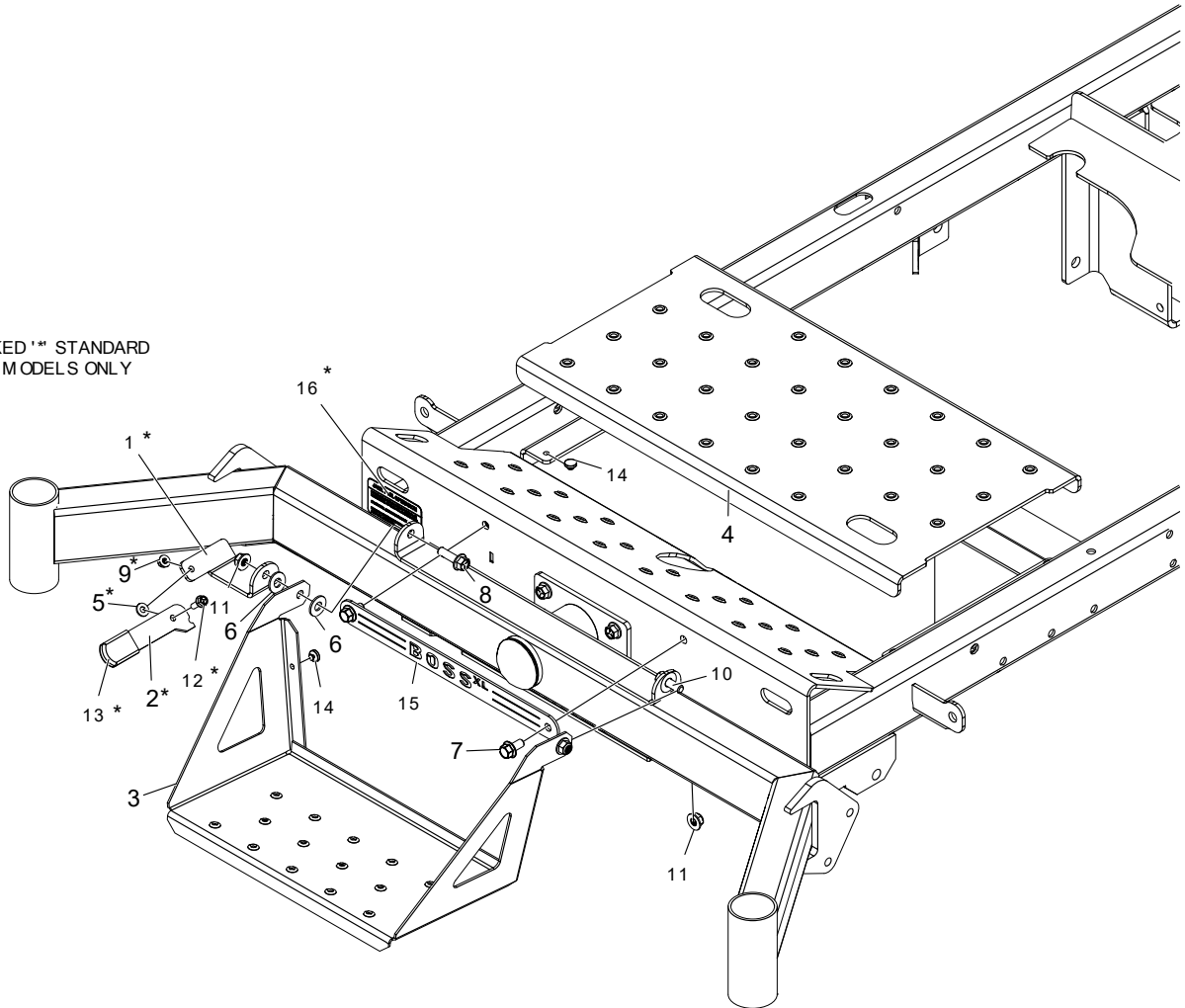

Item #	Qty	Part #	Description
1	1	629-958P	JACK - DRILL ANTI ROTATION STOP
2	1	629-983P	ANTI ROTATION PIVOT STOP
3	1	663-134P	STEP, EXTENDED
4	1	724-044P	FLOOR PAN
5	1	F-1009-01	FLAT WASHER, 1/4", YZ
6	3	F-1009-03	WASHER, FLAT, 3/8, YZ
7	2	F-2124	FHCS, 3/8-16 X 3/4", YZ, GR5
8	1	F-2125	FHCS, 3/8-16 X 1-1/4", YZ, GR5, 72" DECK
-	1	F-2141	FHCS, 3/8-16 X 1", YZ, GR5, 60" DECK
9	1	F-2132	NUT, 1/4-20 NYLOC, FLANGED, YZ
10	1	F-2141	FHCS, 3/8-16 X 1", YZ, GR5
11	4	F-2151	NUT, 3/8-16 NYLOC, FLANGED, YZ
12	1	F-2162	FHCS, 1/4-20 X 3/4", YZ, GR5
13	1	H-1850	GRIP, VINYL
14	6	H-2461	RUBBER BUMPER
15	1	H-2912	PLACARD, BOSS XL
16	1	P-13551	DECAL, JACK TOOL

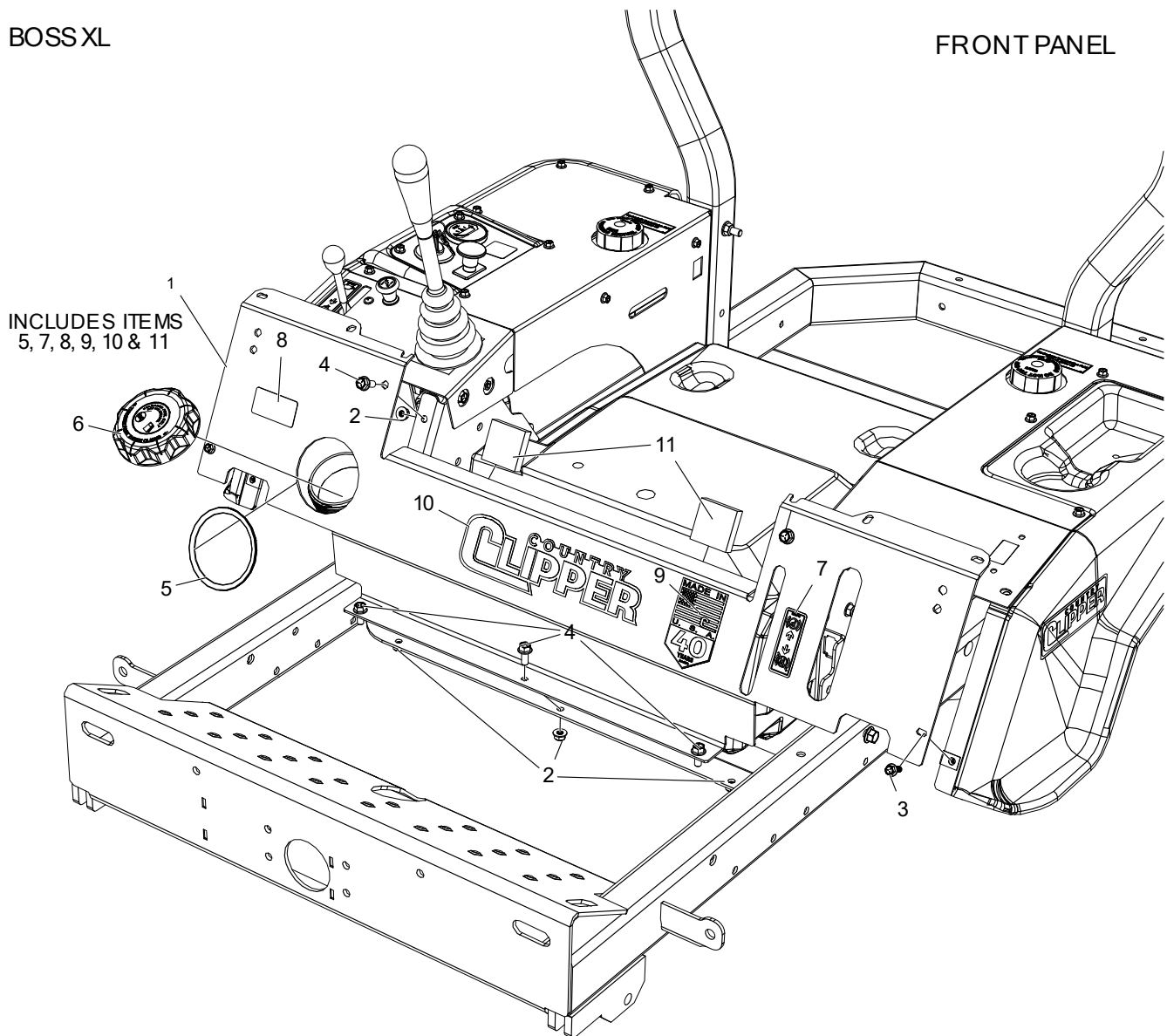

Item #	Qty	Part #	Description
1	1	730-028A	FRONT PANEL W/ DECALS
2	5	F-2063	NUT, 5/16-18, NYLOC, FLANGED, YZ
3	2	F-2119	FHCS, 1/4-20 X 3/4", YZ, GR5, LOCK PATCH
4	5	F-2120	FHCS, 5/16-18 X 3/4", YZ, GR5
5	1	H-1626	"U"-CHANNEL TRIM, 12.5"
6	1	H-3236	RATCHET CAP, W/ SS TETHER, 3.5 DIA
7	1	P-11382	DECAL, PARK BRAKE
8	1	P-13748	DECAL, FUEL SAFETY
9	1	P-13682	DECAL, 40 TH ANNIVERSARY
10	1	P-13312	DECAL, LOGO, CHROME w/BLK, LG
11	1	H-2990	WEATHER-RESISTANT NEOPRENE FOAM (ADHESIVE) 1/2"

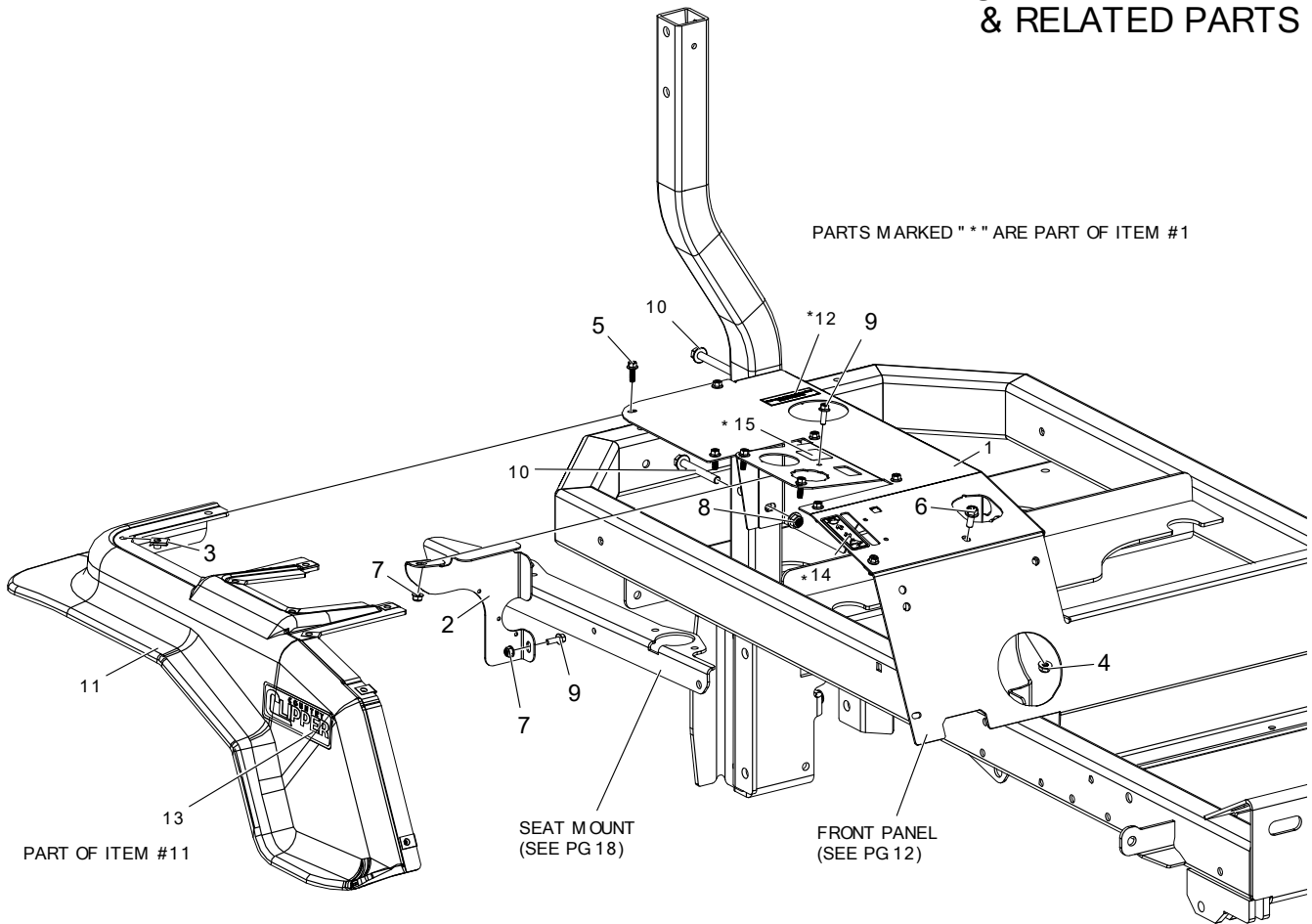

Item #	Qty	Part #	Description
1	1	730-030A	FENDER CAP W/ DECALS, JS, RH
-	1	730-031A	FENDER CAP W/ DECALS, TS, RH
2	1	724-152P	STIFFENER, CONTROL PANEL
3	9	F-1858	U-NUT, 1/4-20
4	1	F-2063	NUT, 5/16-18, NYLOC, FLANGED, YZ
5	9	F-2119	FHCS, 1/4-20 X 3/4", YZ, GR5, LOCK PATCH
6	1	F-2120	FHCS, 5/16-18 X 3/4", YZ, GR5
7	2	F-2132	NUT, 1/4-20 NYLOC, FLANGED, YZ
8	2	F-2151	NUT, 3/8-16 NYLOC, FLANGED, YZ
9	2	F-2162	FHCS, 1/4-20 X 3/4", YZ, GR5
10	2	F-2180	FHCS, 3/8-16 x 3", YZ, GR5
11	1	629-976A	FENDER SKIRT W/ DECAL, RH
12	1	P-11052	DECAL, "TRANSMISSION OIL..."
13	1	P-13366	DECAL, C/C LOGO, SM, VINYL
14	1	P-13481	DECAL, THROTTLE
15	1	P-13750	DECAL, TAKE KEY

LEFT HAND FENDER & RELATED PARTS

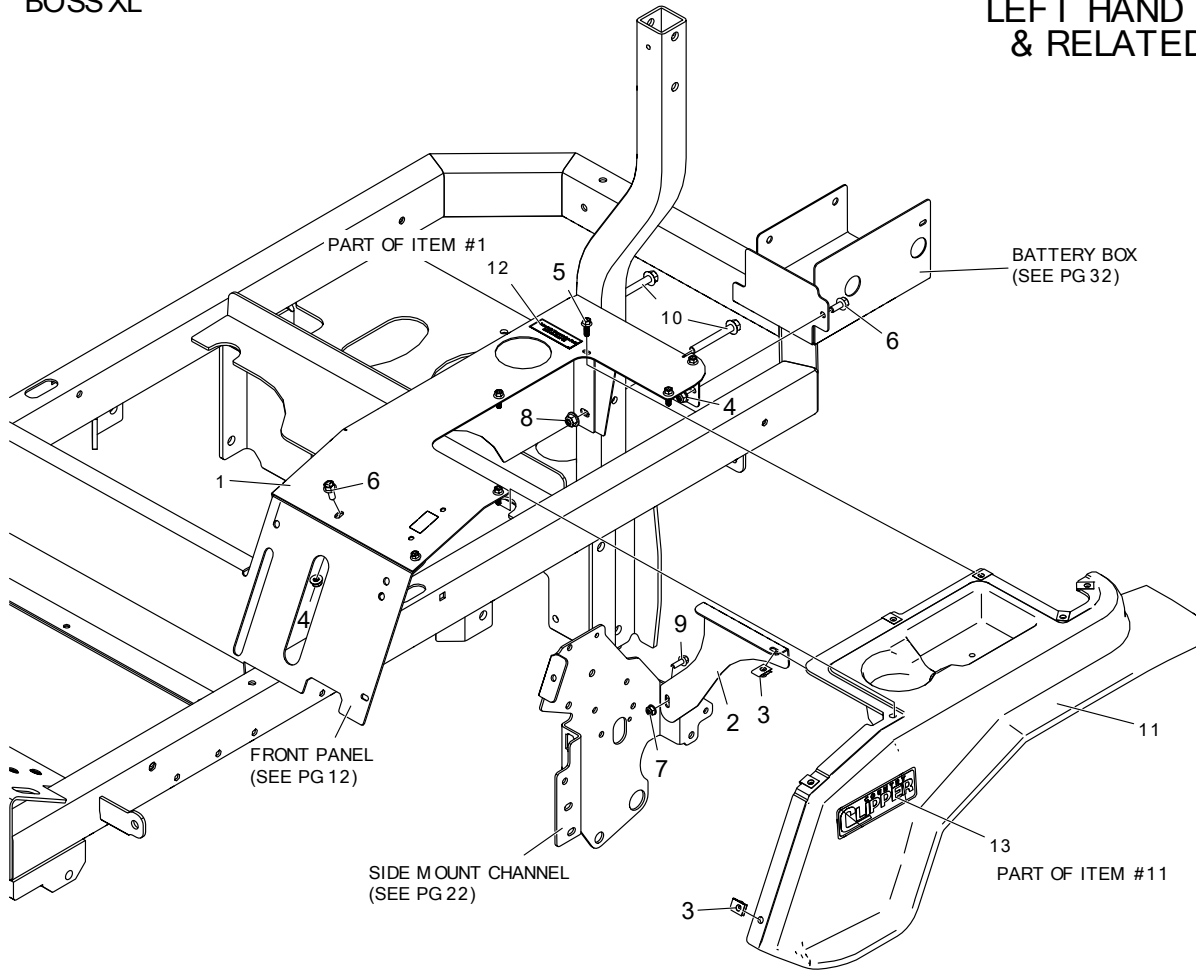

Item #	Qty	Part #	Description
1	1	629-974A	FENDER CAP W/ DECAL, JS, LH
-	1	629-979A	FENDER CAP W/ DECAL, TS, LH
2	1	724-155P	STIFFENER, FENDER CAP, LH
3	7	F-1858	U-NUT, 1/4-20
4	2	F-2063	NUT, 5/16-18, NYLOC, FLANGED, YZ
5	6	F-2119	FHCS, 1/4-20 X 3/4", YZ, GR5, LOCK PATCH
6	2	F-2120	FHCS, 5/16-18 X 3/4", YZ, GR5
7	1	F-2132	NUT, 1/4-20 NYLOC, FLANGED, YZ
8	2	F-2151	NUT, 3/8-16 NYLOC, FLANGED, YZ
9	1	F-2162	FHCS, 1/4-20 X 3/4", YZ, GR5
10	2	F-2180	FHCS, 3/8-16 x 3", YZ, GR5
11	1	629-975A	FENDER SKIRT W/ DECAL, LH
12	1	P-11052	DECAL, "TRANSMISSION OIL..."
13	1	P-13366	DECAL, C/C LOGO, SM, VINYL

BOSS XL

ENGINE GUARD

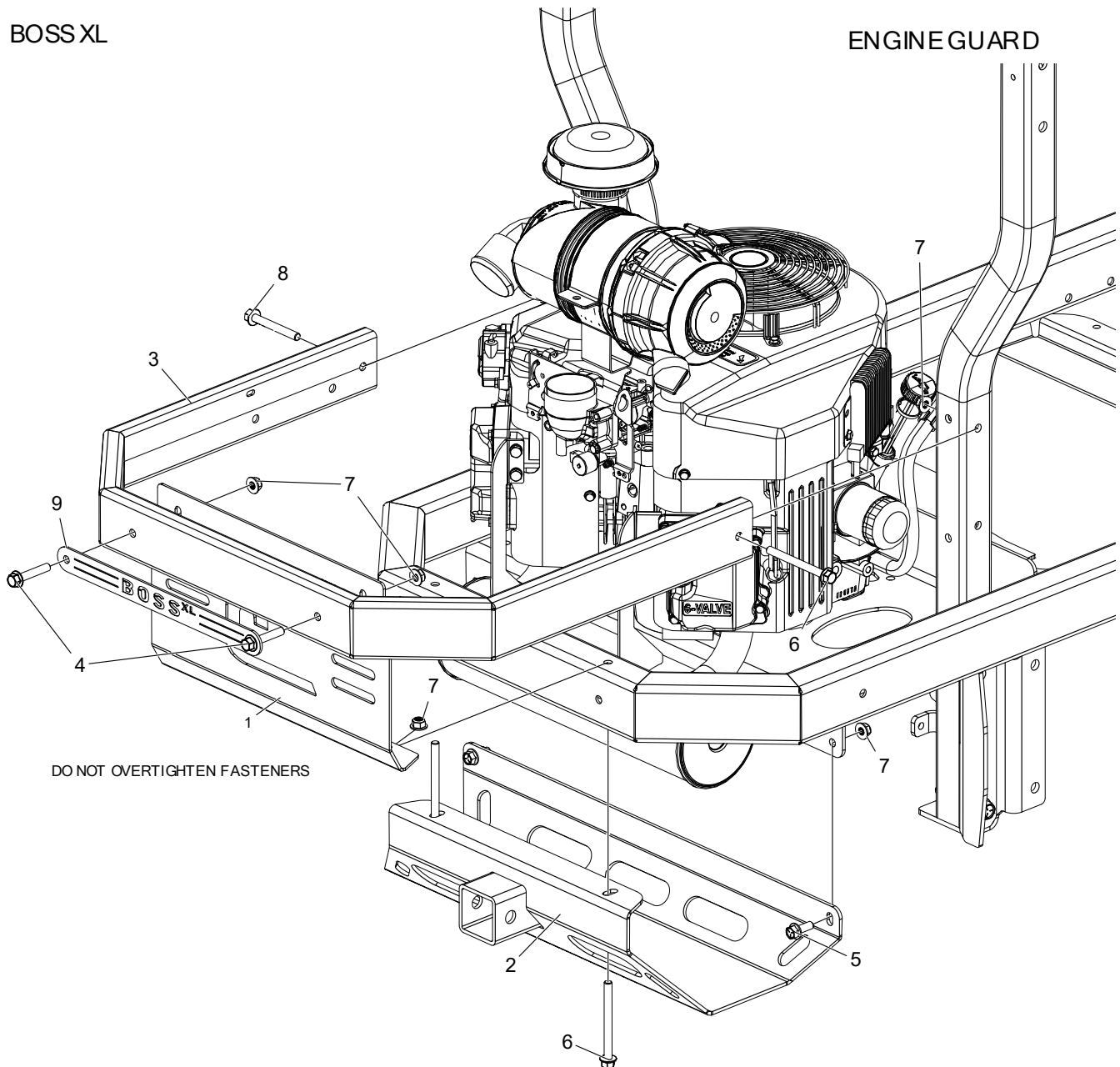

DO NOT OVERTIGHTEN FASTENERS

Item #	Qty	Part #	Description
1	1	724-160P	ENGINE GUARD
2	1	724-140W	WLDT, MUFFLER GUARD W/ HITCH
3	1	724-166W	WLDT, ENGINE WRAP
4	2	F-2126	FHCS, 3/8-16 X 2", YZ, GR5
5	2	F-2141	FHCS, 3/8-16 X 1", YZ, GR5
6	3	F-2142	FHCS, 3/8-16 X 4", YZ, GR5
7	8	F-2151	NUT, 3/8-16 NYLOC, FLANGED, YZ
8	1	F-2180	FHCS, 3/8-16 X 3", YZ, GR5
9	1	H-2912	PLACARD, BOSS XL

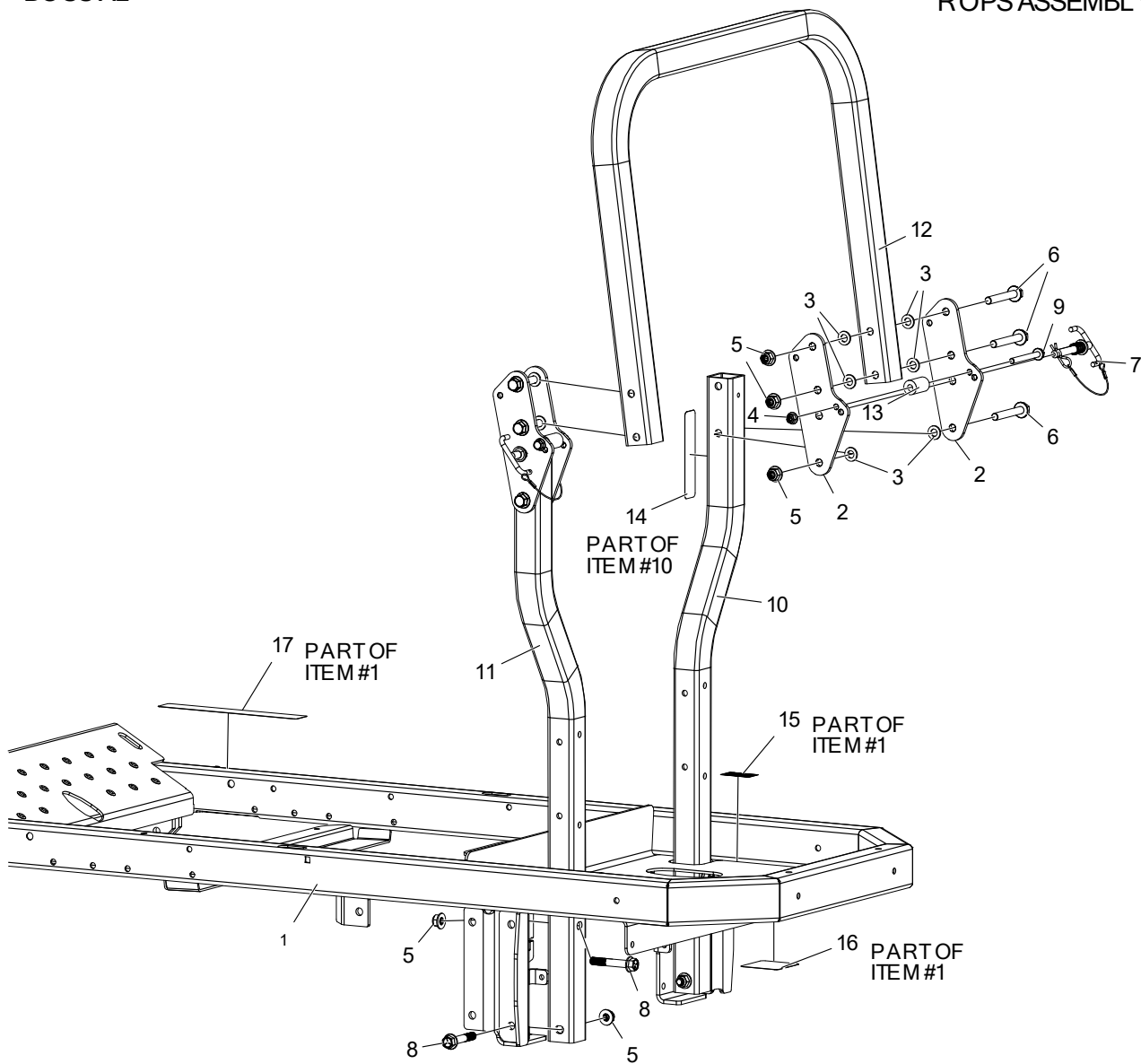

Item #	Qty	Part #	Description
1	1	730-029A	WLDT, FRAME W/ DECALS
2	4	724-107P	HINGE PLATE, ROPS
3	12	F-1521	WASHER, 1/2" CUSTOM, YZ
4	2	F-2151	NUT, 3/8-16 NYLOC, FLANGED, YZ
5	10	F-2152	NUT, 1/2-13 NYLOC, FLANGED, YZ
6	6	F-2163	FHCS, 1/2-13 X 3-1/2", YZ, GR5
7	2	F-2208	PULL-PIN ASSEMBLY, T-HANDLE
8	4	F-2300	FHCS, 1/2-13 X 3", YZ, GR5
9	2	F-2303	FHCS, 3/8-16 x 3-1/2", YZ, GR5
10	1	629-977A	TUBE, POST - ROPS W/ DECAL
11	1	H-3104	TUBE, POST - ROPS
12	1	H-3105	TUBE, TOP LOOP - ROPS
13	2	H-3148	BUMPER, URETHANE
14	1	P-13480	DECAL, WARNING ROPS
15	1	P-10777	PATENT DECAL
16	1	P-12918	DECAL, HYDRO BELT ROUTING
17	1	P-13751	DECAL, SAFETY

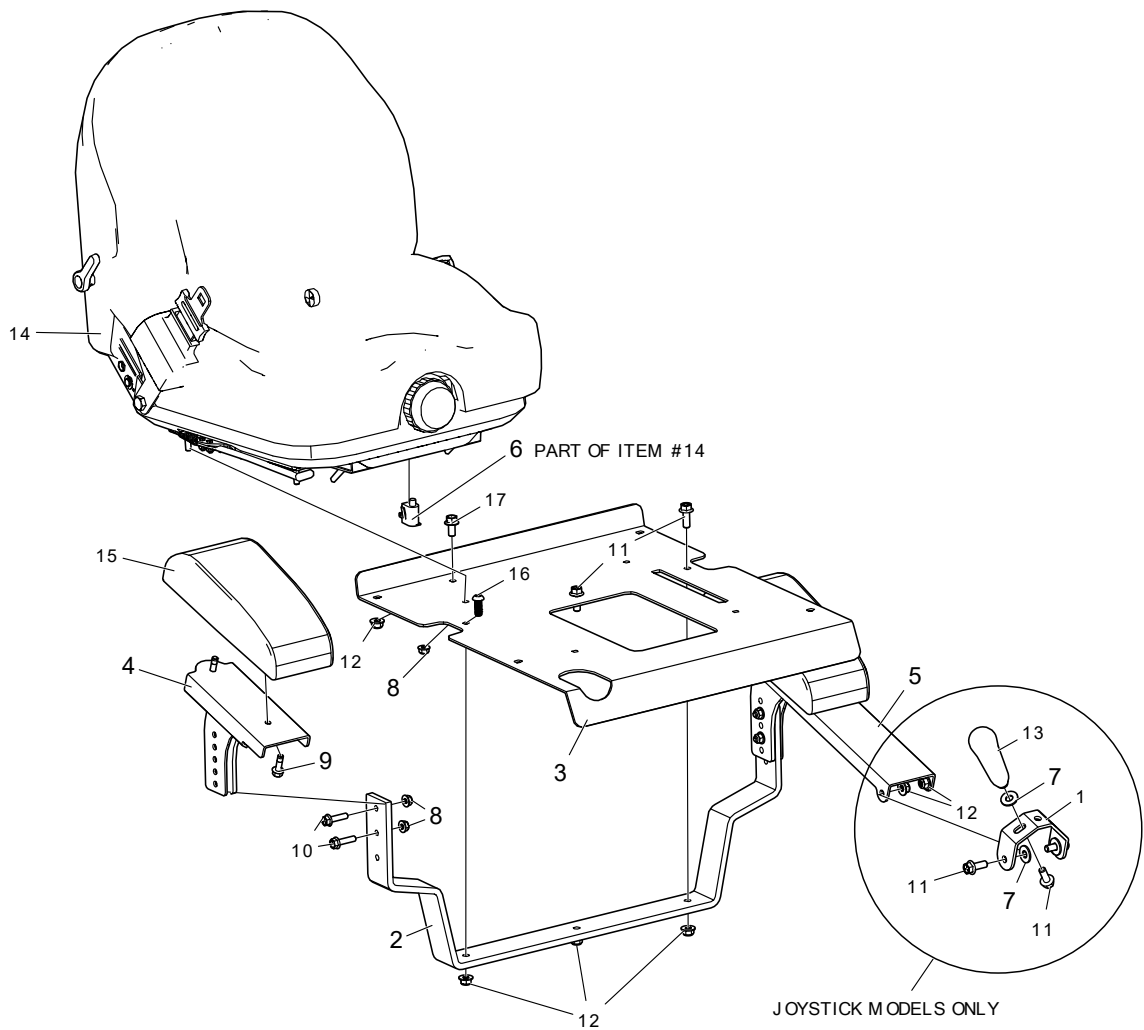

Item #	Qty	Part #	Description
1	1	724-075P	SECURITY GRIP MOUNT
2	1	724-105P	ARM REST MOUNT
3	1	724-116P	SEAT PAN
4	1	724-124W	WLDT, ARM REST MOUNT
5	1	724-125W	WLDT, ARM REST MOUNT, JS
-	1	724-124W	WLDT, ARM REST MOUNT, TS
6	1	E-6491	SEAT SWITCH
7	3	F-1009-03	WASHER, FLAT, 3/8, YZ
8	8	F-2063	NUT, 5/16-18, NYLOC, FLANGED, YZ
9	4	F-2121	FHCS, 5/16-18 X 1", LOCK PATCH, YZ, GR5
10	4	F-2122	FHCS, 5/16-18 X 1-1/4", YZ, GR5, FULL THD
11	5	F-2141	FHCS, 3/8-16 X 1", YZ, GR5
12	6	F-2151	NUT, 3/8-16 NYLOC, FLANGED, YZ
13	1	H-2764	HANDLE, JOYSTICK
14	1	H-2788	SEAT, BOSS XL
-	1	H-2916	BACK COVER FOR SEAT H-2788
15	2	H-2799	PAD, ARM REST
16	1	F-2311	BUTTON, SHCS, 3/8-16 X 1"
17	1	F-2124	FHCS, 3/8-16 X 3/4", YZ, GR5

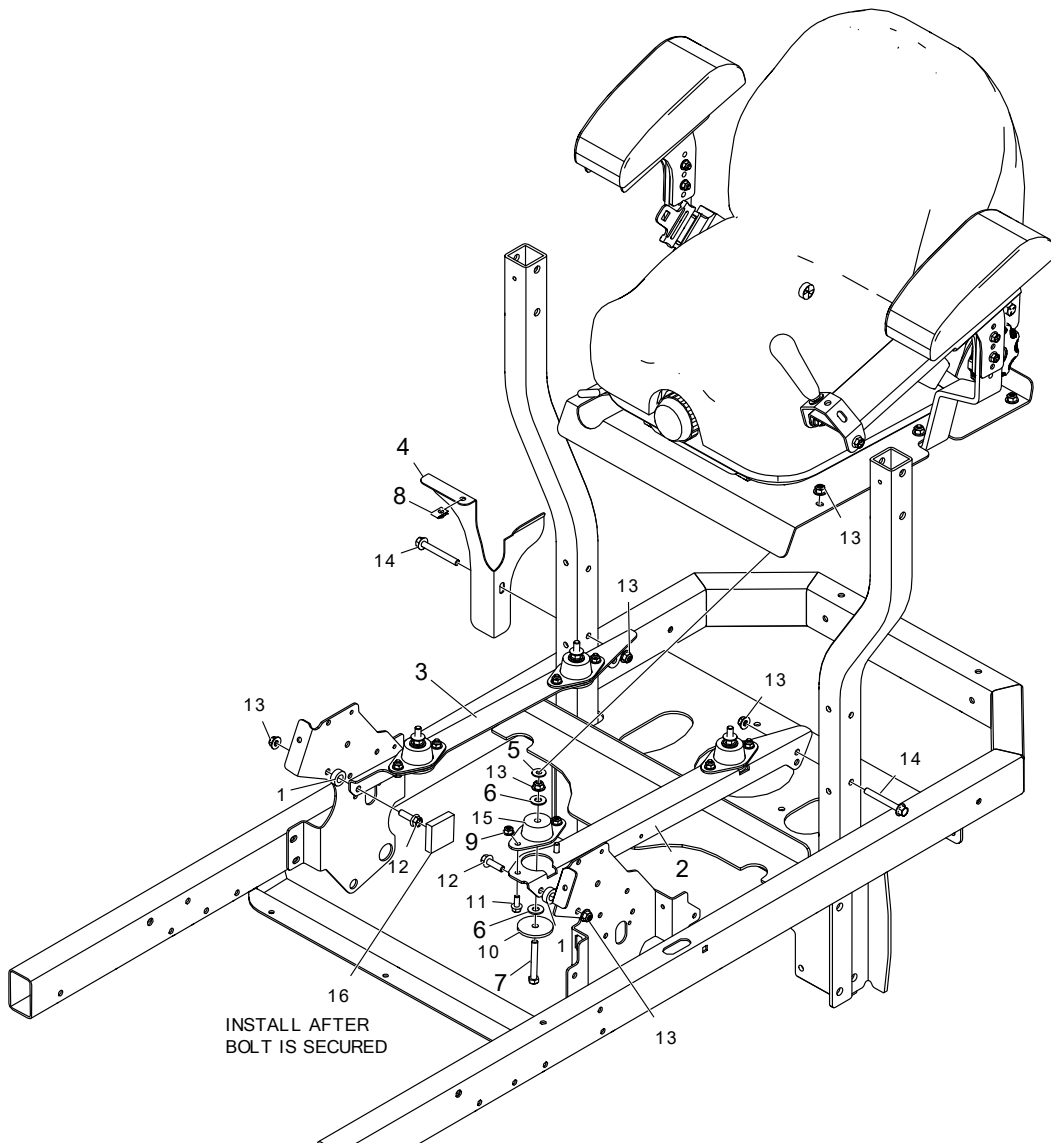

Item #	Qty	Part #	Description
1	2	660-038P	SPACER, 3/8" WIDE
2	1	724-043P	SEAT MOUNT ANGLE, LH
3	1	724-109P	SEAT MOUNT ANGLE, RH
4	1	724-153P	STIFFENER, FENDER CAP
5	4	F-1009-02	WASHER, FLAT
6	8	F-1009-03	WASHER, FLAT, 3/8, YZ
7	4	F-1542	HHCS, 3/8-16 X 2-3/4", YZ, GR5
8	1	F-1858	U-NUT, 1/4-20
9	8	F-2063	NUT, 5/16-18, NYLOC, FLANGED, YZ
10	4	F-2102	WASHER, 2.25 OD X .406 ID X 7GA, YZ
11	8	F-2120	FHCS, 5/16-18 X 3/4", YZ, GR5
12	2	F-2125	FHCS, 3/8-16 X 1-1/4", YZ, GR5
13	12	F-2151	NUT, 3/8-16 NYLOC, FLANGED, YZ
14	2	F-2180	FHCS, 3/8-16 x 3", YZ, GR5
15	4	H-2734	ISOLATOR, VIBRATION
16	1	H-2990	WEATHER-RESISTANT NEOPRENE FOAM (ADHESIVE) 1/2"

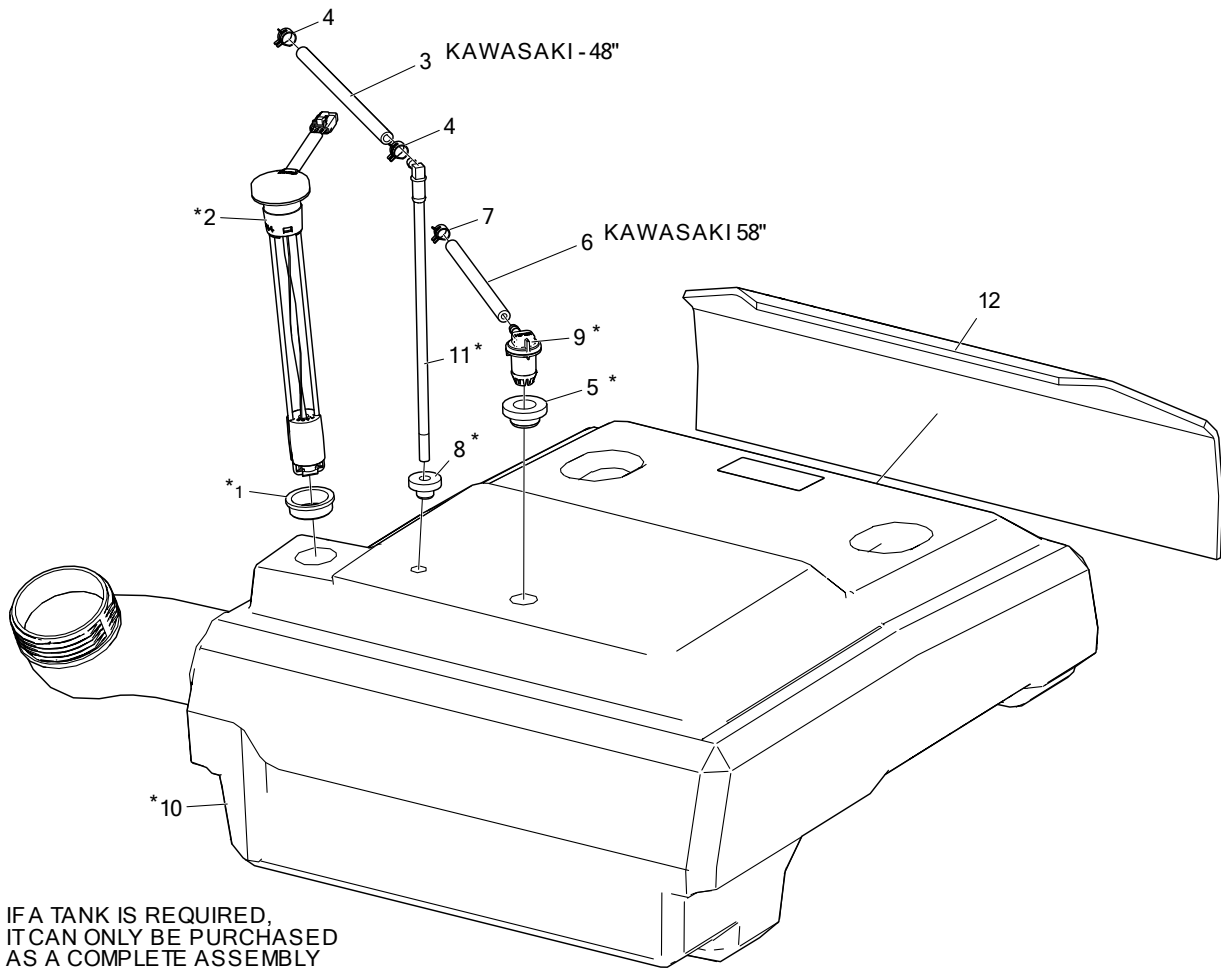

IF A TANK IS REQUIRED,
IT CAN ONLY BE PURCHASED
AS A COMPLETE ASSEMBLY
{H-3224}

(PARTS MARKED '*' ARE INCLUDED IN ASS'Y)

Item #	Qty	Part #	Description
1	1	E-6820	GROMMET, NITRILE
2	1	E-6806	RESISTIVE OUTPUT GAUGE
3	1	H-1648	FUEL LINE, 1/2" O.D., 1/4" I.D.
4	2	H-1687	1/2 O.D. HOSE SPRING CLAMP
5	1	H-2679	REMOTE VENT GROMMET
6	1	H-2697	HOSE, FUEL LINE .188 ID X .406 OD
7	1	H-2698	CLAMP, .406 OD FUEL LINE
8	1	H-2741	GROMMET, PICK UP TUBE
9	1	H-2831	REMOTE VENT ASSY
10	1	H-3224	ASSEMBLY, FUEL TANK, LG, BLK
11	1	H-3175	PICK UP TUBE
12	1	H-3185	HEAT SHIELD, ADHESIVE BACK

JOYSTICK CONTROL
& RELATED PARTS

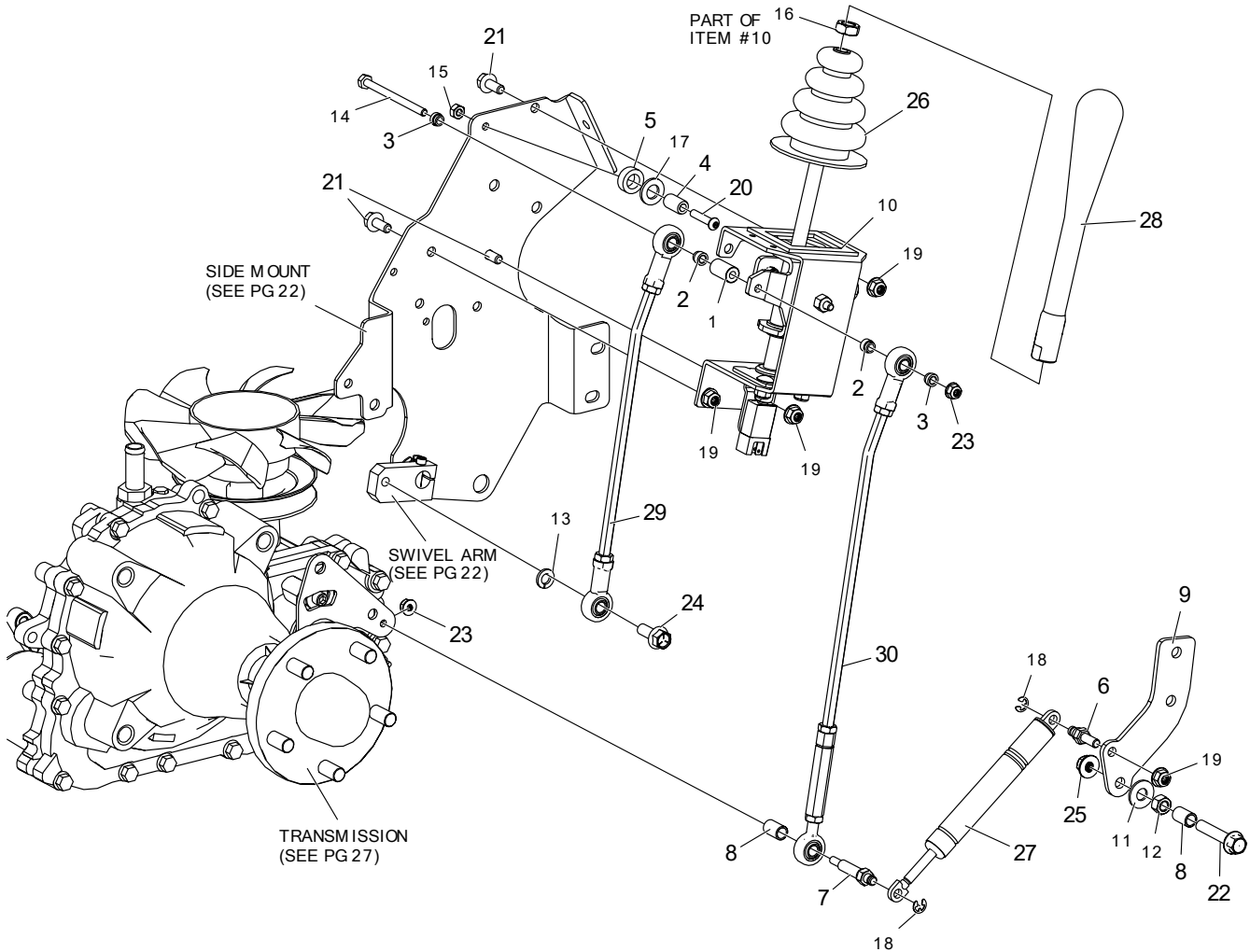

Item #	Qty	Part #	Description
1	1	625-100P	TUBE, PIVOT, JOYSTICK
2	2	625-107P	BUSHING, .375 ROD END
3	2	625-116P	BUSHING, .375 ROD END, SHORT
4	1	625-119P	PIN, PIVOT, JS, LONG
5	1	625-126P	SPACER, JOYSTICK PANEL
6	1	638-028P	DAMPER BOLT 5/16-18 X 3/4"
7	1	707-072P	STUD, LINKAGE MOUNT
8	2	707-073P	STAND-OFF, LINKAGE MOUNT
9	1	724-028P	DISCONNECT BRACKET
10	1	720-161A	JOYSTICK ASSEMBLY
11	1	F-1009-03	WASHER, FLAT, 3/8, YZ
12	1	F-1011-03	NUT, HEX, 3/8-16, YZ
13	1	F-1019-03	LOCKWASHER, HVY, 3/8, YZ
14	1	F-1020-01	CAPSCREW, 1/4-20 X 3-1/2", YZ, GR5
15	1	F-1158	NUT, CENTERLOCK, 1/4-20, YZ, GR5

Item #	Qty	Part #	Description
16	1	F-1462	JAM NUT, 1/2-20, RH, YZ
17	1	F-1521	WASHER, 1/2" CUSTOM, YZ
18	2	F-1610	RETAINING RING, EXTERNAL
19	4	F-2063	NUT, 5/16-18, NYLOC, FLANGED, YZ
20	1	F-2103	SHCS, BUTTON HD, 1/4-20 X 1-1/4", CZ
21	3	F-2120	FHCS, 5/16-18 X 3/4", YZ, GR5
22	1	F-2126	FHCS, 3/8-16 X 2", YZ, GR5
23	2	F-2132	NUT, 1/4-20 NYLOC, FLANGED, YZ
24	1	F-2141	FHCS, 3/8-16 X 1", YZ, GR5
25	1	F-2151	NUT, 3/8-16 NYLOC, FLANGED, YZ
26	1	H-1991	JOY STICK BOOT
27	1	H-2843	DAMPER
28	1	H-2964	HANDLE, JOYSTICK
29	1	H-3151	LINKAGE, INNER
30	1	H-3152	LINKAGE, OUTER

JOYSTICK ASSEMBLY
{720-161A}

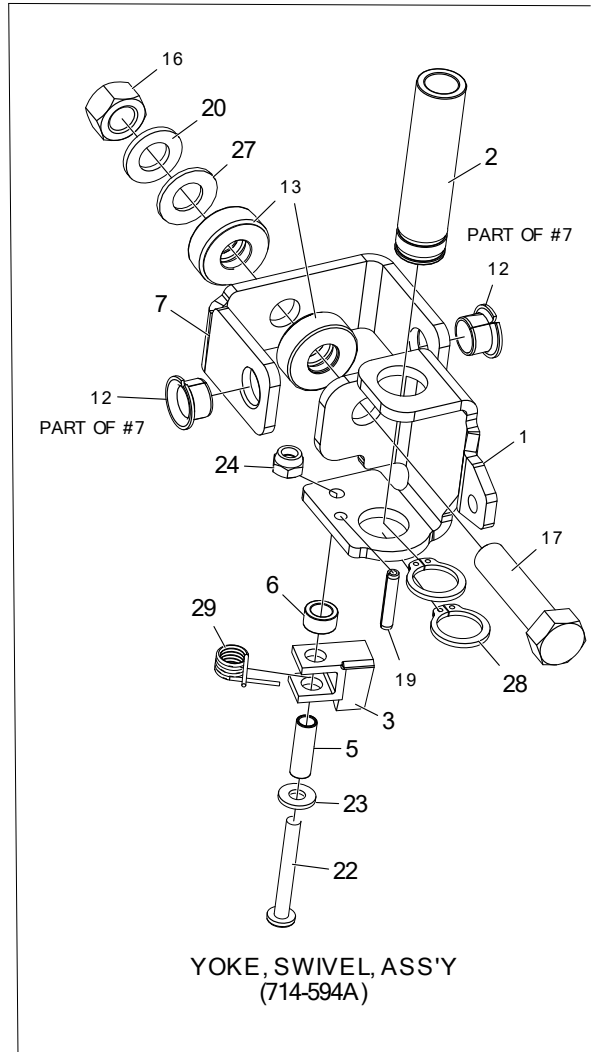
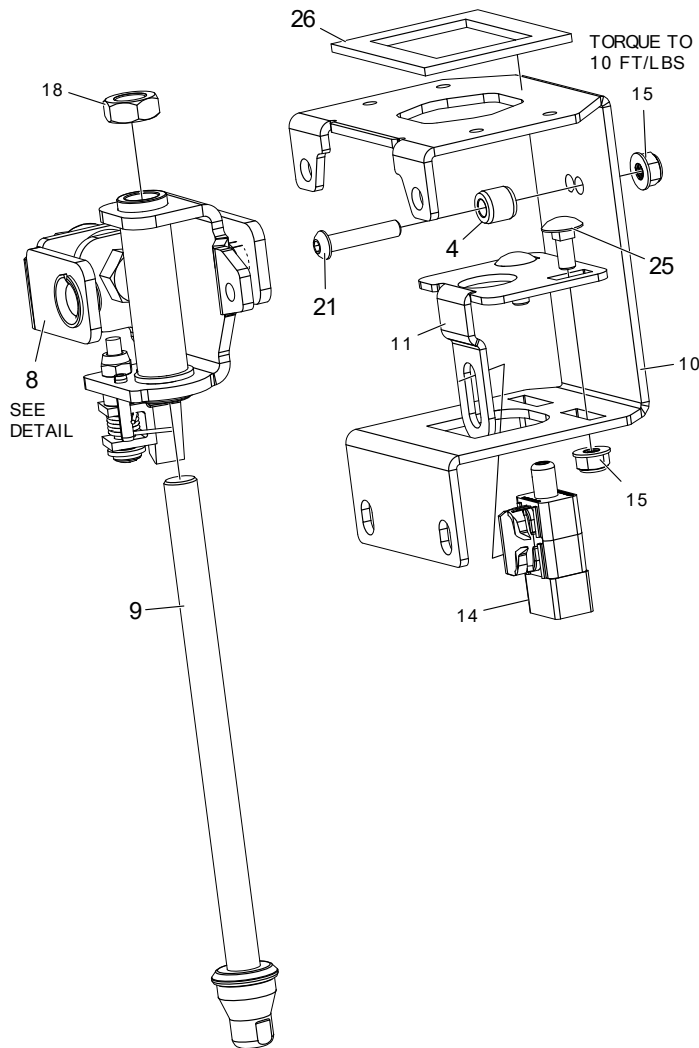

Item #	Qty	Part #	Description
1	1	625-096P	YOKE, SWIVEL, JOYSTICK
2	1	625-099P	TUBE, GUIDE, CONTROL ROD
3	1	714-593P	TAB, CAM DETENT
4	1	625-106P	PIN, PIVOT, JS
5	1	625-124P	TUBE-SPACER, DETENT CAM
6	1	625-125P	SPACER, CAM DETENT
7	1	625-128A	PIVOT ASSEMBLY
8	1	714-594P	YOKE, SWIVEL ASSEMBLY
9	1	709-169A	ROD ASSEMBLY, SHORT, 1/2"
10	1	724-113P	JOYSTICK HOUSING - DOUBLE SIDED
11	1	724-114P	JOYSTICK NEUTRAL PLATE
12	2	D-3784	BUSHING, DU 1/2 DIA X 3/8 WIDE
13	2	D-3931	THRUST BEARING
14	1	E-6692	PLUNGER SWITCH, RAIL MOUNT
15	3	F-2132	NUT, FLANGED, 1/4-20 w/NYLOC, YZ

Item #	Qty	Part #	Description
16	1	F-1005-05	NUT, 1/2-13, CENTERLOCK, YZ, GR5
17	1	F-1293	HHCS, 1/2-13 X 2", YZ, GR5
18	1	F-1462	JAM NUT, 1/2-20, RH, YZ
19	1	F-1503	PIN, SPIROL 3/16 DIA X 1 X .010 THK
20	1	F-1521	WASHER, 1/2" CUSTOM, YZ
21	1	F-2103	SHCS, BUTTON HD, 1/4-20 X 1", CZ
22	1	F-2135	SCREW, PANHEAD, PHILLIPS #12-24 X 1.75 CZ
23	1	F-2136	WASHER, FLAT, #12 PLAIN, CZ
24	1	F-2137	NUT, #12-24, NYLOCK
25	2	F-2155	BOLT, CARRIAGE, 1/4-20 X 5/8", YZ, GR5
26	1	H-1947	JOYSTICK GASKET
27	1	H-2704	SPRING, BELLEVILLE, .50 X 1 X .073
28	2	H-2705	RING, RETAINING, .75 EXT.
29	1	H-2710	SPRING, DETENT, JOYSTICK

JOYSTICK ASSEMBLY MOUNTING & RELATED PARTS

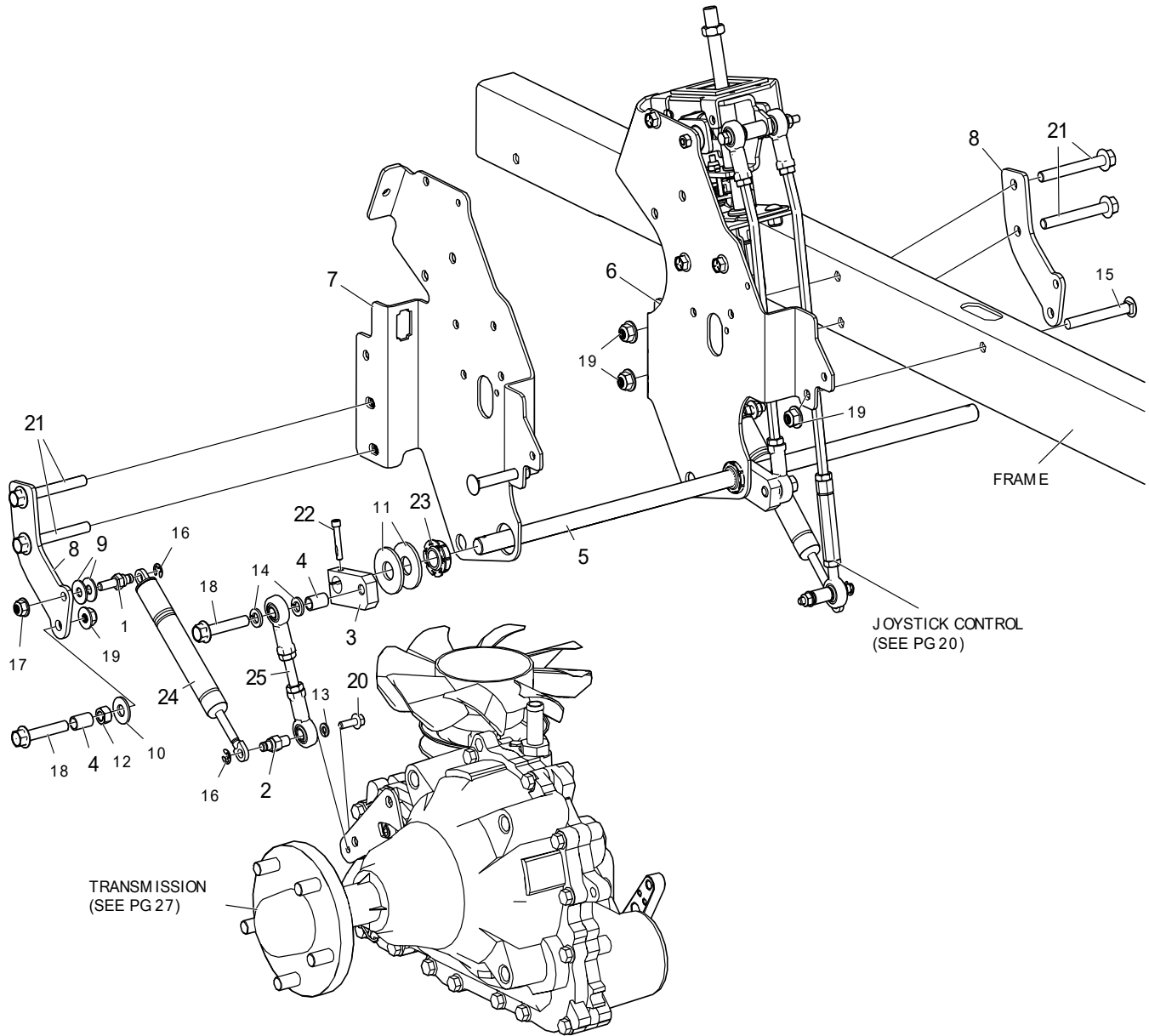

Item #	Qty	Part #	Description
1	1	638-028P	DAMPER BOLT 5/16-18 X 3/4"
2	1	663-051P	DAMPNER STUD, FEMALE
3	2	700-151P	ARM, SWIVEL
4	2	707-073P	STAND-OFF, LINKAGE MOUNT
5	1	709-229P	SHIFT ROD
6	1	724-017P	SIDE MOUNT CHANNEL, RH
7	1	724-018P	SIDE MOUNT CHANNEL, LH
8	2	724-028P	DISCONNECT BRACKET
9	2	F-1009-02	WASHER, FLAT
10	1	F-1009-03	WASHER, FLAT, 3/8
11	2	F-1009-06	WASHER, FLAT, 5/8
12	1	F-1011-03	NUT, HEX, 3/8-16, YZ
13	1	F-1019-01	WASHER, LOCK, 1/4, YZ

Item #	Qty	Part #	Description
14	2	F-1019-03	LOCKWASHER, HVY, 3/8, YZ
15	2	F-1024-01	BOLT, CARRIAGE, 3/8-16 X 3, CZ, GR5
16	2	F-1610	RETAINING RING, EXTERNAL
17	1	F-2063	NUT, 5/16-18, NYLOC, FLANGED, YZ
18	2	F-2126	FHCS, 3/8-16 X 2", YZ, GR5
19	7	F-2151	NUT, 3/8-16 NYLOC, FLANGED, YZ
20	1	F-2162	FHCS, 1/4-20 X 3/4", YZ, GR5
21	4	F-2180	FHCS, 3/8-16 x 3", YZ, GR5
22	2	F-2231	SHCS, 12-24 X 1-1/4", CZ, LOCK PATCH
23	2	H-2773	BEARING, FLANGED-SPHERICAL
24	1	H-2843	DAMPER
25	1	H-2926	LINKAGE, UPPER, JS

TWIN LEVER CONTROL & RELATED PARTS

(RIGHT SIDE SHOWN)

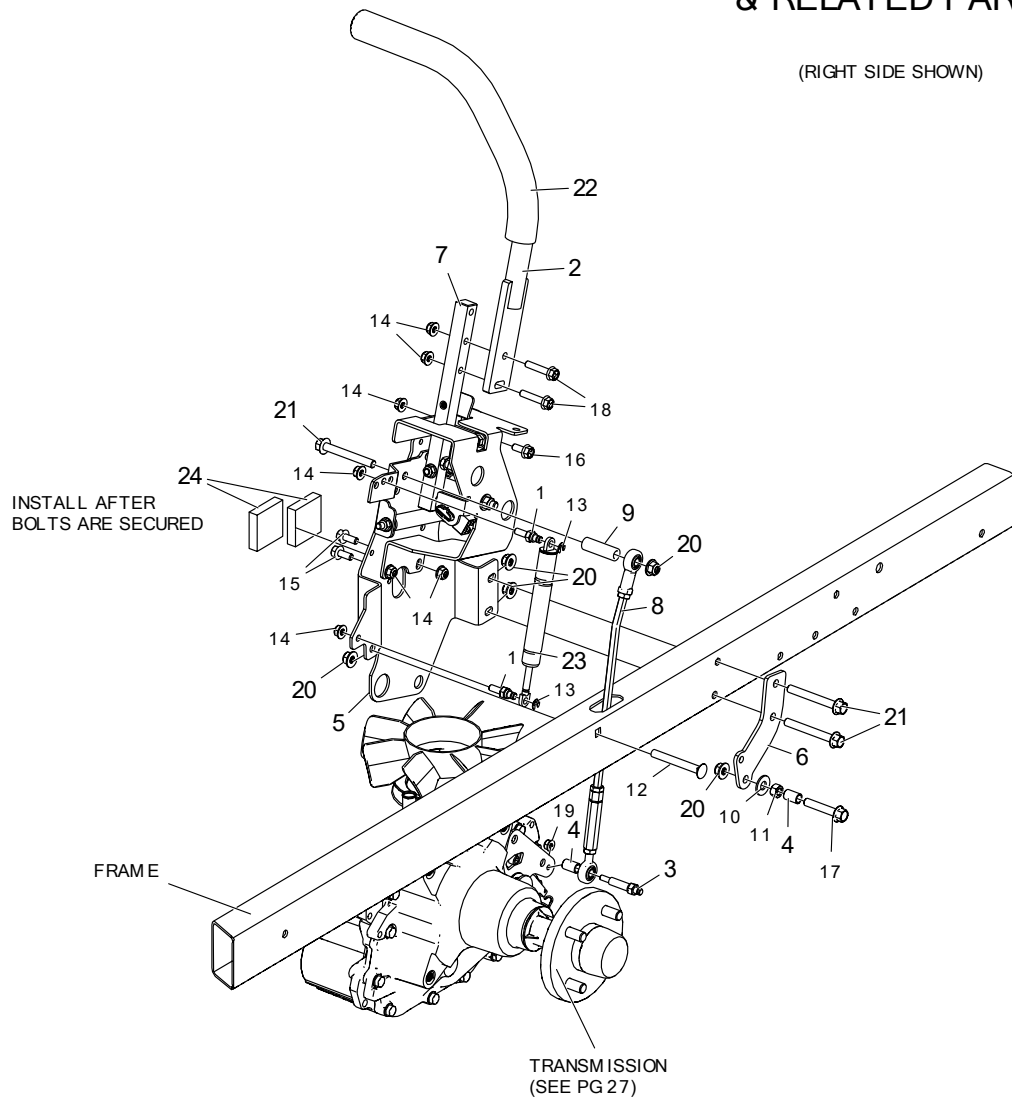

Item #	Qty	Part #	Description
1	2	638-028P	DAMPER BOLT 5/16-18 X 3/4"
2	1	659-375W	WLDT, DUAL LEVER
3	1	707-072P	STUD, LINKAGE MOUNT
4	2	707-073P	STAND-OFF, LINKAGE MOUNT
5	1	724-017P	SIDE MOUNT CHANNEL, RH
-	1	724-018P	SIDE MOUNT CHANNEL, LH
6	1	724-028P	DISCONNECT BRACKET
7	1	724-136A	ASSY, TS CONTROL, RH
-	1	724-137A	ASSY, TS CONTROL, LH
8	1	724-141P	LINKAGE, OUTER, TS
9	1	724-150P	SPACER, TWINSTICK LINKAGE
10	1	F-1009-03	WASHER, FLAT, 3/8, YZ
11	1	F-1011-03	NUT, HEX, 3/8-16, YZ

Item #	Qty	Part #	Description
12	1	F-1024-01	BOLT, CARRIAGE, 3/8-16 X 3, CZ, GR5
13	2	F-1610	RETAINING RING, EXTERNAL
14	7	F-2063	NUT, 5/16-18, NYLOC, FLANGED, YZ
15	2	F-2120	FHCS, 5/16-18 X 3/4", YZ, GR5, RH
-	2	F-2148	FHCS, 5/16-18 X 1", YZ, GR5, LH
16	1	F-2120	FHCS, 5/16-18 X 3/4", YZ, GR5
17	1	F-2126	FHCS, 3/8-16 X 2", YZ, GR5
18	2	F-2129	FHCS, 5/16-18 X 1-1/2", YZ, GR5
19	1	F-2132	NUT, 1/4-20 NYLOC, FLANGED, YZ
20	5	F-2151	NUT, 3/8-16 NYLOC, FLANGED, YZ
21	3	F-2180	FHCS, 3/8-16 X 3", YZ, GR5
22	1	H-2739	GRIP, 15", CLOSED END
23	1	H-2843	DAMPER
24	2	H-2990	WEATHER-RESISTANT NEOPRENE FOAM (ADHESIVE) 1/2"

TWIN LEVER ASSEMBLY

{714-136A - RIGHT SIDE}
{714-137A - LEFT SIDE}

(RIGHTSIDE SHOWN)

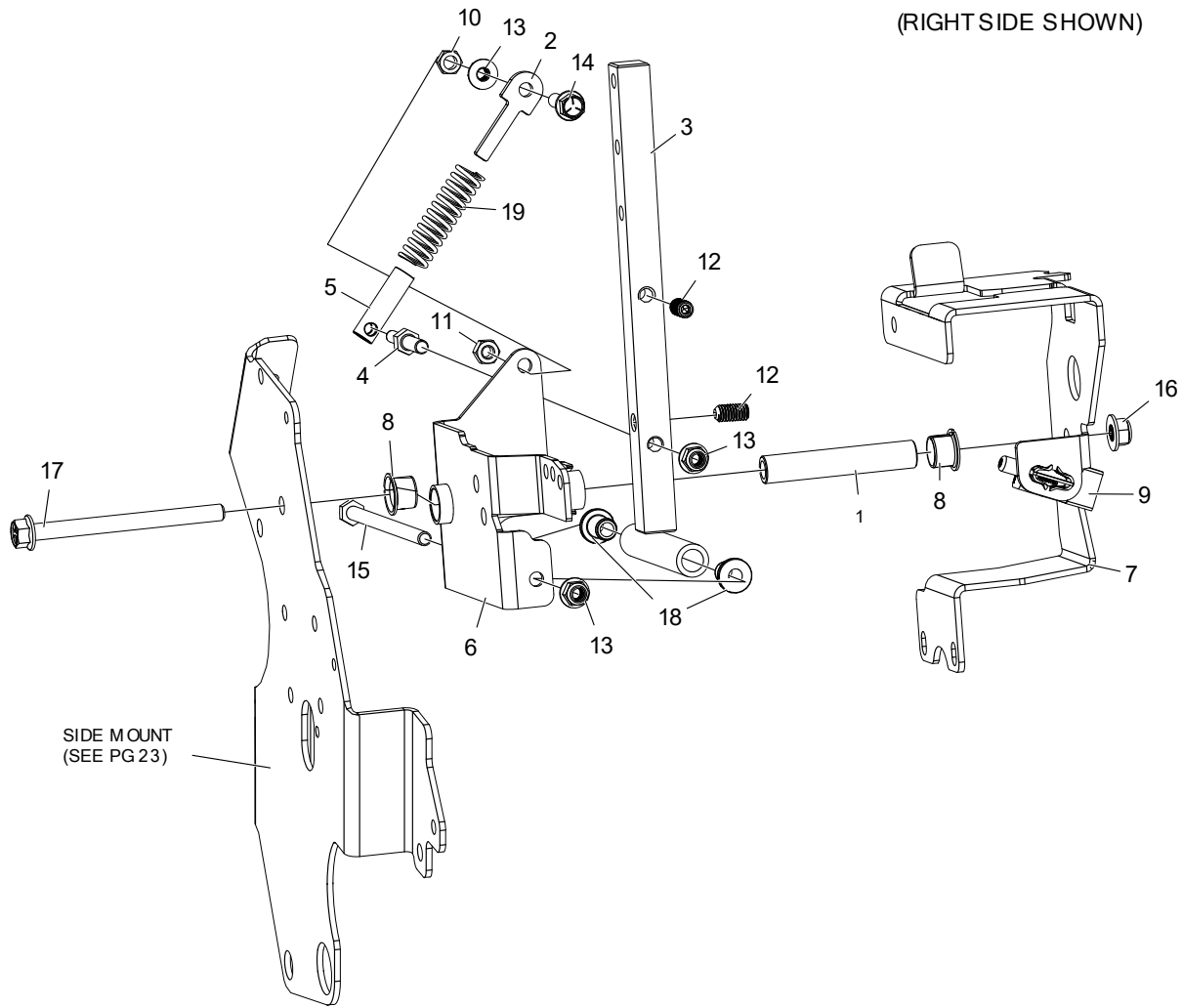

Item #	Qty	Part #	Description
1	1	714-074P	PIN, PIVOT, TWIN LEVER
2	1	721-006P	SPRING GUIDE, TS
3	1	721-090W	WLDT, HANDLE BASE
4	1	721-093P	PIN, SPRING OVER-CENTER
5	1	721-094P	SPRING GUIDE, TS OVER-CENTER
6	1	724-130W	WLDT, TWIN STICK PIVOT, RH
-	1	724-132W	WLDT, TWIN STICK PIVOT, LH
7	1	724-134P	HOUSING, TWIN STICK, RH
-	1	724-135P	HOUSING, TWIN STICK, LH
8	2	D-3730	BUSHING, DU 5/8 DIA X 1/2 LG
9	1	E-6692	PLUNGER SWITCH, RAIL MOUNT
10	1	F-1011-02	NUT, HEX 5/16-18
11	1	F-1125	NUT, CENTERLOCK, 5/16-18, YZ, GR5
12	2	F-1903	SETSCREW, 3/8-16 X 3/4" W/ NYLON
13	3	F-2063	NUT, 5/16-18, NYLOC, FLANGED, YZ
14	1	F-2122	FHCS, 5/16-18 X 1-1/4", YZ, GR5, FULL THD
15	1	F-2145	HHCS, 5/16-18 X 6", YZ, GR8
16	1	F-2151	NUT, 3/8-16 NYLOC, FLANGED, YZ
17	1	F-2160	FHCS, 3/8-16 X 4-1/2", YZ, GR5
18	2	H-3009	BUSHING, 0.313, NYLON, FLANGED
19	1	H-3079	SPRING, TS OVER CENTER

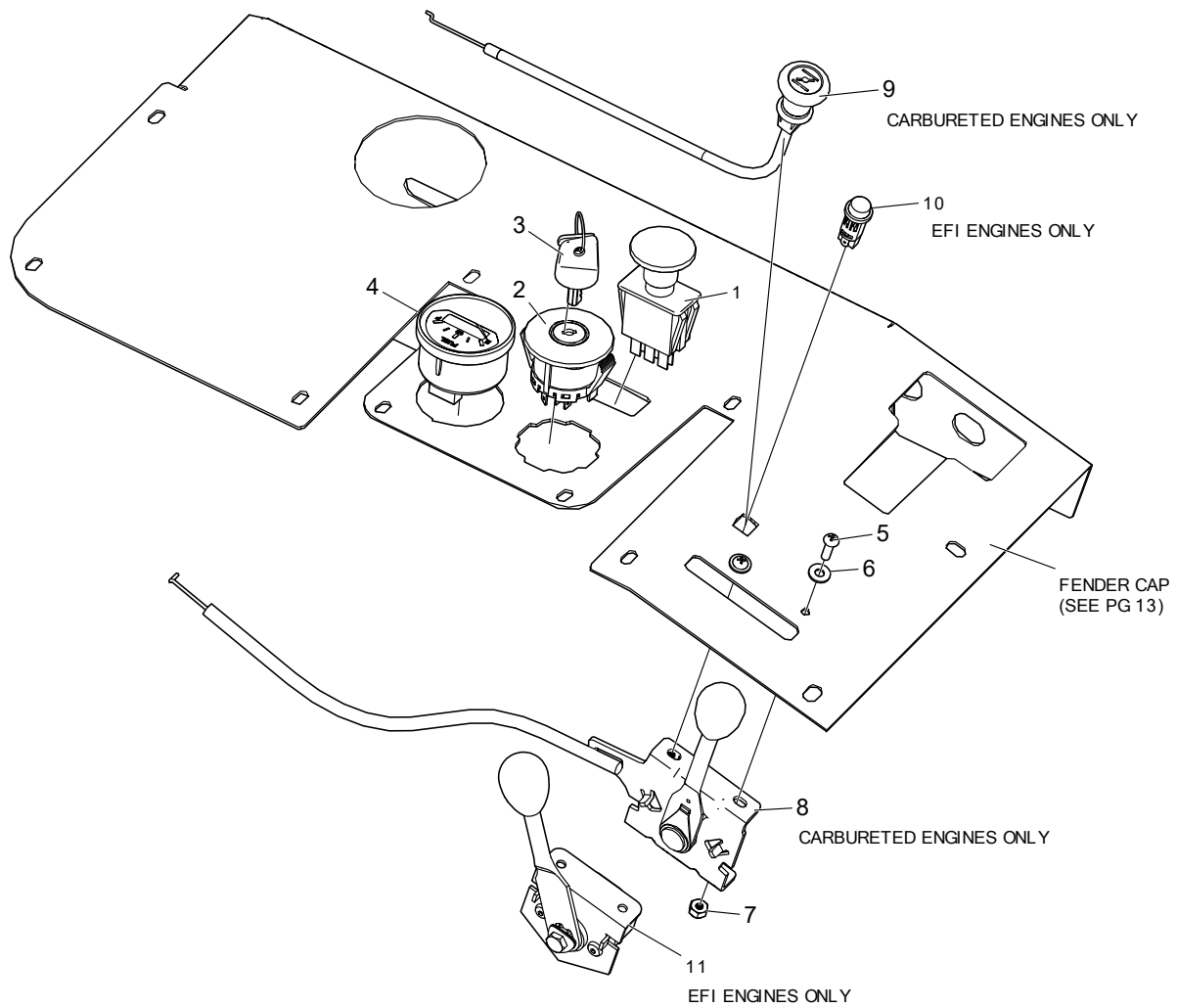

Item #	Qty	Part #	Description
1	1	E-6403	PTO SWITCH
2	1	E-6717	IGNITION SWITCH, 4-POSITION W/ PLASTIC KEYWAY
3	1	E-6718	KEY ASSEMBLY
4	1	E-6797	HOUR METER, FUEL GAUGE
5	2	F-1022-26	MACHINE SCREW, RND, 10-32 X 5/8, SLOTTED, CZ
6	2	F-1071	WASHER, FLAT #10, ZINC PLATED
7	2	F-1448	LOCKNUT, 10-32 NYLOC YELLOW PLTD
8	1	H-3164	THROTTLE CABLE (54.50"), KAWASAKI
9	1	H-3166	CHOKE CABLE (50.00")
10	1	E-6314	INCANDESCENT LIGHT, 12V, RED
11	1	E-6784	EFI THROTTLE LEVER ASSEMBLY

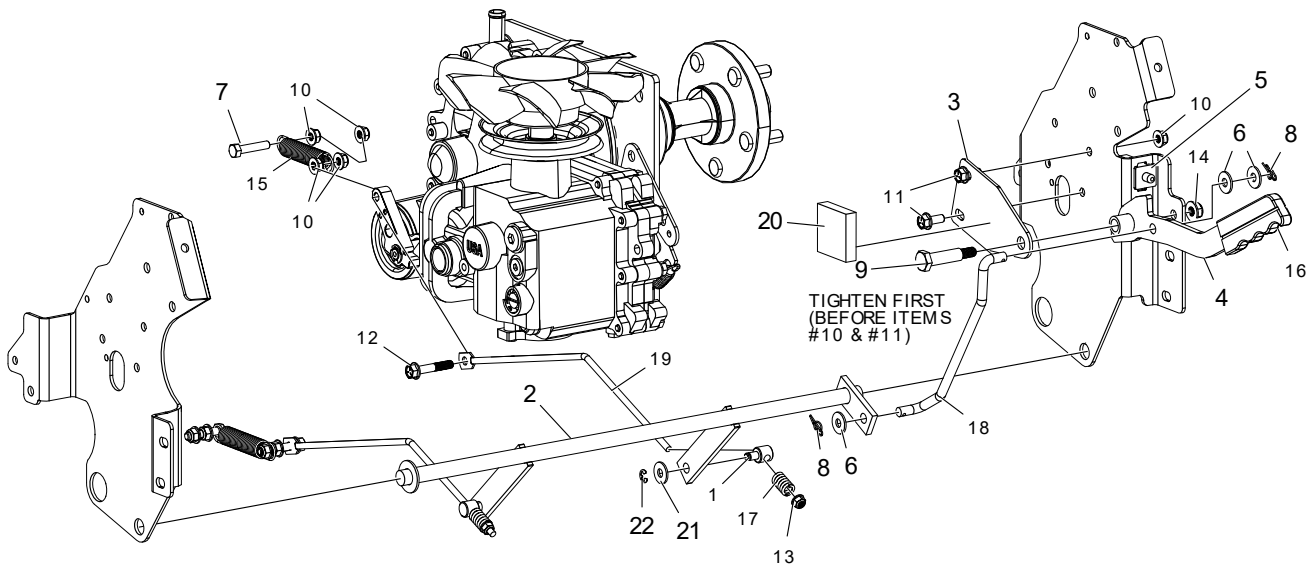

Item #	Qty	Part #	Description
1	2	714-522P	BRAKE STUD
2	1	724-034W	WLDT, BRAKE ROD
3	1	724-040P	BRAKE HANDLE MOUNT PLATE
4	1	724-054W	WLDT, BRAKE HANDLE
5	1	E-6474	SWITCH, SNAP MOUNT
6	3	F-1009-03	WASHER, FLAT, 3/8, YZ
7	2	F-1015-17	HHCS, 5/16-18 X 1-1/2", YZ, GR5
8	2	F-1492	RUE RING, 5/16
9	1	F-2061	SHOULDER BOLT, .50 DIA X 1.625, HEX HEAD
10	10	F-2063	NUT, 5/16-18, NYLOC, FLANGED, YZ
11	2	F-2148	FHCS, 5/16-18 X 1", YZ, GR5
12	2	F-2123	FHCS, 5/16-18 X 1-3/4", YZ, GR5
13	2	F-2132	NUT, 1/4-20 NYLOC, FLANGED, YZ
14	1	F-2151	NUT, 3/8-16 NYLOC, FLANGED, YZ
15	2	H-1635	SPRING, EXT, 3/4" OD X 4" OAL
16	1	H-1926	1/4" X 1" HANDLE GRIP
17	2	H-2786	SPRING, COMP, 0.562 X 0.88 HGT
18	1	H-3101	LINK ROD, BRAKE HANDLE
19	2	H-3136	BRAKE LINK ROD
20	1	H-2990	WEATHER-RESISTANT NEOPRENE FOAM (ADHESIVE) 1/2"
21	2	F-1009-02	WASHER, FLAT, 5/16", YZ
22	2	F-1610	RETAINING RING

TRANSMISSION & RELATED PARTS

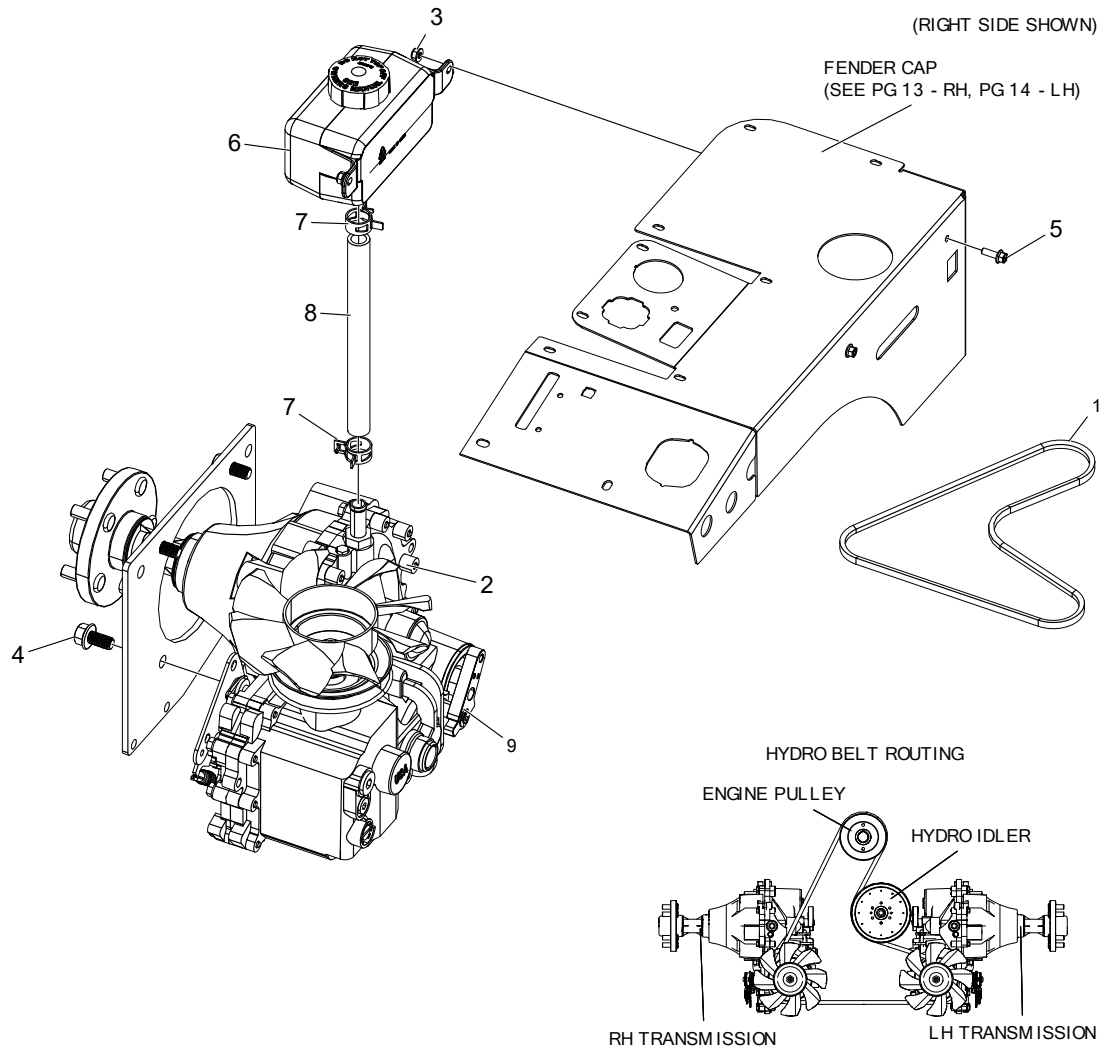

Item #	Qty	Part #	Description
1	1	D-3900	V-BELT, B-71 KEVLAR
2	1	D-4203-01	TRANSAXLE, ZT-5400, RH, RTN, 8 BLADE FAN
-	1	D-4203-02	TRANSAXLE, ZT-5400, LH, RTN, 8 BLADE FAN
3	2	F-2132	NUT, 1/4-20 NYLOC, FLANGED, YZ
4	4	F-2143	FHCS, 1/2-13 X 1", YZ, GR5
5	2	F-2162	FHCS, 1/4-20 X 3/4", YZ, GR5
6	1	H-2735	TANK, HYDRO EXPANSION
7	2	H-3090	HOSE CLAMP, 1" HOSE O.D.
8	1	H-3161	HOSE, 5/8" ID x 9-3/4", HI-TEMP
9	1	H-3208	OIL FILTER, FITS ZT-5400

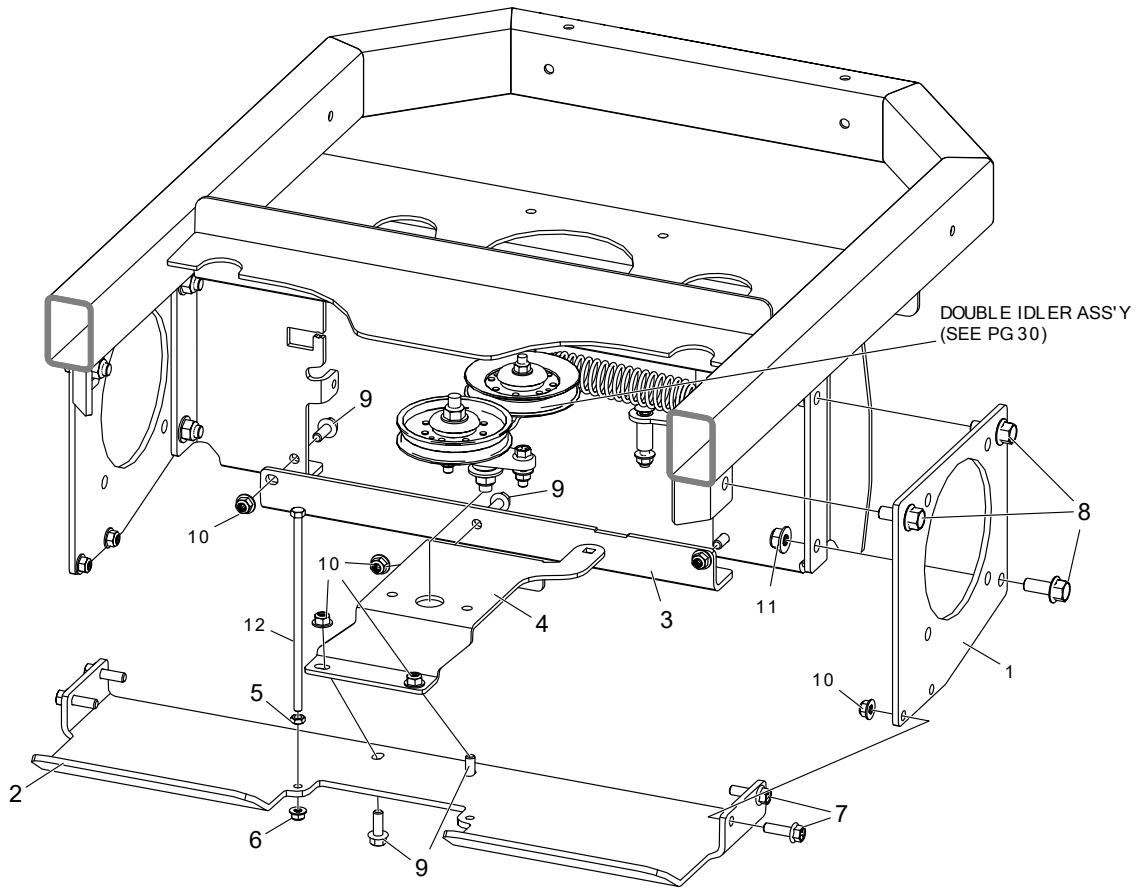

Item #	Qty	Part #	Description
1	2	724-015P	HYDRO MOUNT PLATE
2	1	724-016P	HYDRO MOUNT BRACE
3	1	724-046P	DOUBLE IDLER TENSION ARM
4	1	724-048P	DOUBLE IDLER MOUNTING BRACKET
5	1	F-1125	NUT, HEX 5/16-18, CENTERLOCKING
6	1	F-2063	NUT, 5/16-18, NYLOC, FLANGED, YZ
7	4	F-2125	FHCS, 3/8-16 X 1-1/4", YZ, GR5
8	6	F-2127	FHCS, 1/2-13 X 1-1/4", YZ, GR5
9	5	F-2141	FHCS, 3/8-16 X 1", YZ, GR5
10	9	F-2151	NUT, 3/8-16 NYLOC, FLANGED, YZ
11	6	F-2152	NUT, 1/2-13 NYLOC, FLANGED, YZ
12	1	F-2156	HHCS, 5/16-18 X 8-1/2", YZ, GR5

(LOOKING AT BOTTOM)

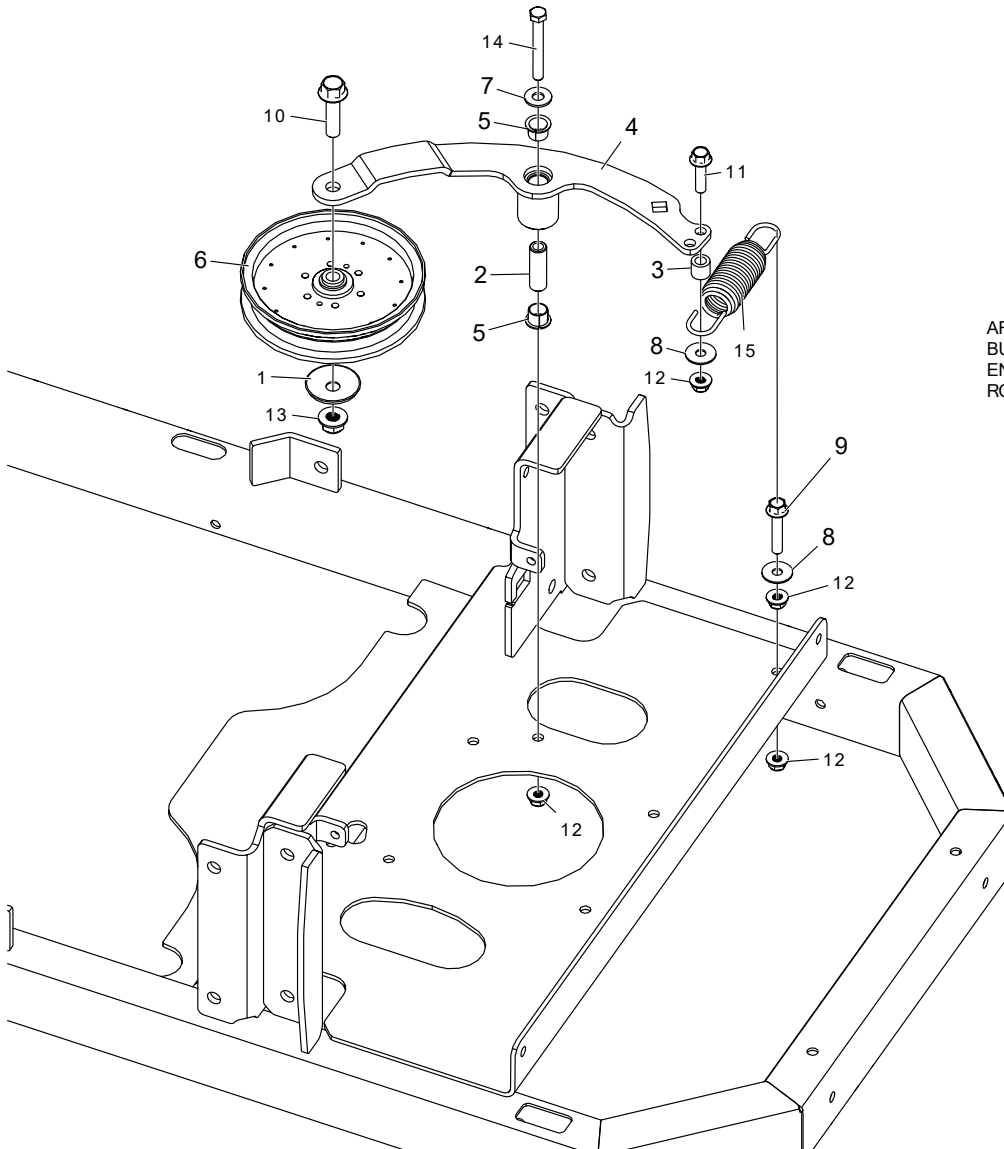

AFTER PRESSING IN
BUSHINGS (ITEM #5),
ENSURE PIN (ITEM #2)
ROTATES FREELY

Item #	Qty	Part #	Description
1	1	620-201P	WASHER, BEARING CAP
2	1	709-077P	MOUNTING PIN
3	1	709-123P	SPACER, BELT TENSION
4	1	724-059W	WLDT, HYDRO IDLER ARM
5	2	D-3730	BUSHING, DU 5/8 DIA X 1/2 LG
6	1	D-3903	PULLEY, FLAT IDLER, 6" (NTN)
7	1	F-1009-03	WASHER, FLAT, 3/8, YZ
8	2	F-2083	WASHER, FENDER, 3/8", YZ
9	1	F-2126	FHCS, 3/8-16 X 2", YZ, GR5
10	1	F-2128	FHCS, 1/2-13 X 2", YZ, GR5
11	1	F-2147	FHCS, 3/8-16 X 1-1/2", YZ, GR5
12	4	F-2151	NUT, 3/8-16 NYLOC, FLANGED, YZ
13	1	F-2152	NUT, 1/2-13 NYLOC, FLANGED, YZ
14	1	F-2207	HHCS, 3/8-16 X 3", YZ, GR8
15	1	H-2995	SPRING, TAPPERED, LONG HOOK

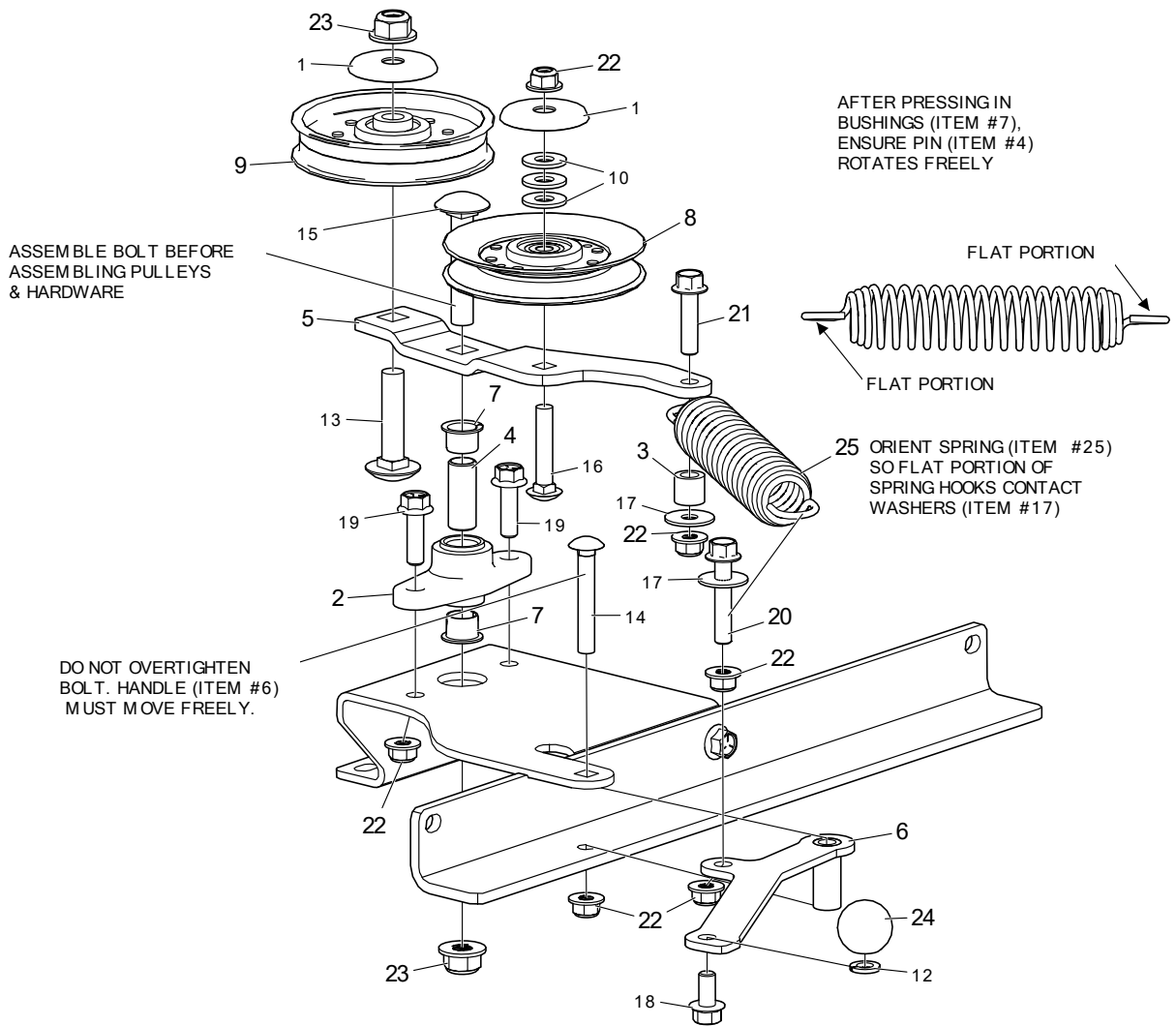

Item #	Qty	Part #	Description
1	2	620-201P	WASHER, BEARING CAP
2	1	660-039P	MOUNT, DOUBLE IDLER
3	1	709-123P	SPACER, BELT TENSION
4	1	722-031P	MOUNTING PIN
5	1	724-049P	DOUBLE IDLER ARM
6	1	724-065W	WLDT, DBL IDLER RELEASE HANDLE
7	2	D-3730	BUSHING, DU 5/8 DIA X 1/2 LG
8	1	D-4191	PULLEY, V-IDLER, 4.937 OD, SPLIT STEEL
9	1	D-3924	PULLEY, FLAT IDLER, 4.25 OD, NTN, DBL INSERT
10	3	F-1009-03	WASHER, FLAT, 3/8, YZ
12	1	F-1019-03	LOCKWASHER, HVY, 3/8, YZ
13	1	F-1822	BOLT, CARRIAGE, 1/2-13 X 2-1/4", YZ, GR5

Item #	Qty	Part #	Description
14	1	F-1865	CARRIAGE BOLT, 3/8-16 X 2-1/2", YZ, GR5
15	1	F-1927	CARRIAGE BOLT, 1/2-13 X 2-3/4"
16	1	F-1976	BOLT, CARRIAGE, 3/8-16 X 2", YZ, GR5
17	2	F-2083	WASHER, FENDER, 3/8", YZ
18	1	F-2124	FHCS, 3/8-16 X 3/4", YZ, GR5
19	2	F-2125	FHCS, 3/8-16 X 1-1/4", YZ, GR5
20	1	F-2126	FHCS, 3/8-16 X 2", YZ, GR5
21	1	F-2147	FHCS, 3/8-16 X 1-1/2", YZ, GR5
22	7	F-2151	NUT, 3/8-16 NYLOC, FLANGED, YZ
23	2	F-2152	NUT, 1/2-13 NYLOC, FLANGED, YZ
24	1	H-2405	BALL, 1-1/4"
25	1	H-2619	SPRING, 5 X 1-1/2, TAPERED ENDS

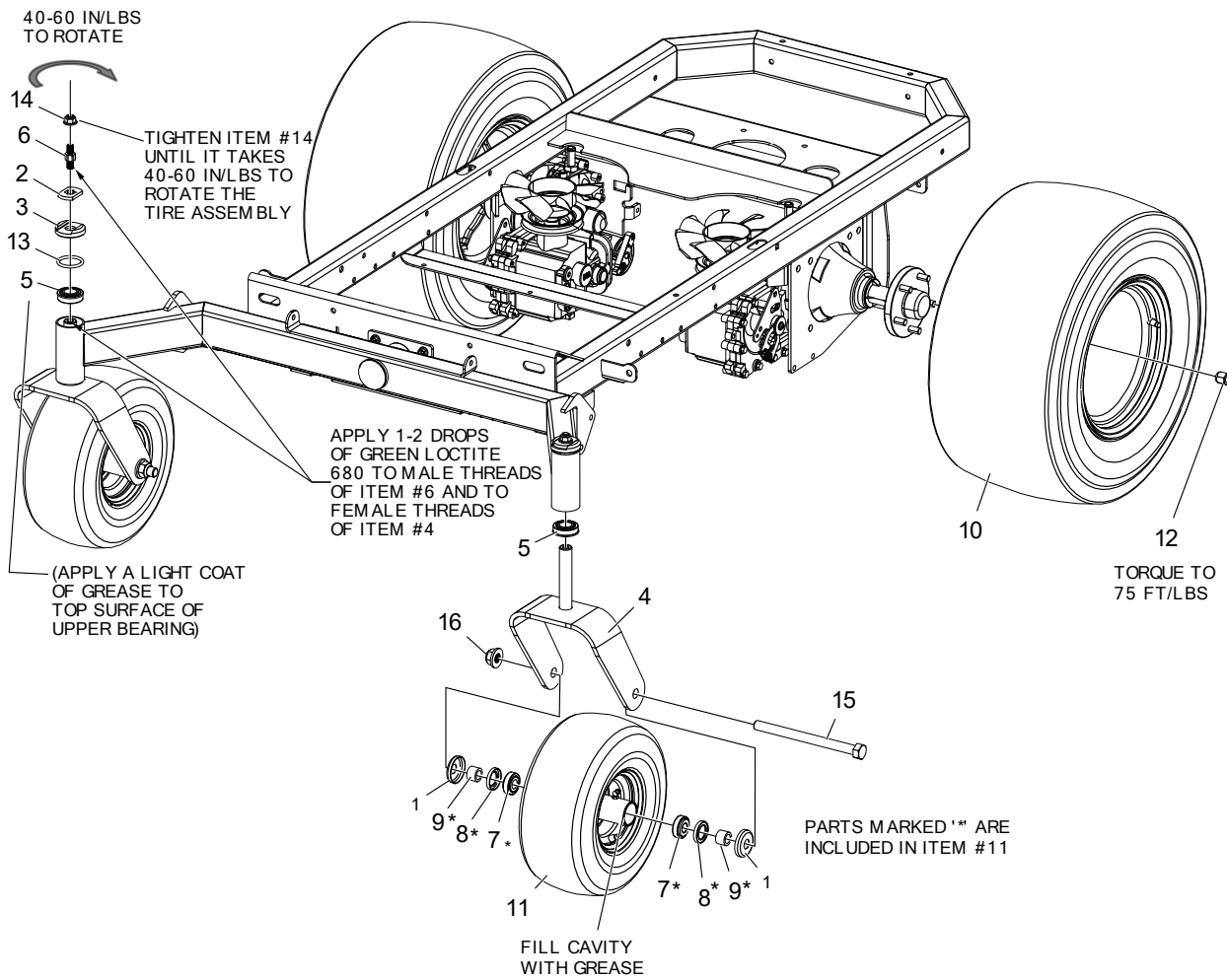

Item #	Qty	Part #	Description
1	4	663-221P	CAP, WHEEL BEARING
2	2	714-589P	CASTER BRAKE DRIVE WASHER
3	2	H-3267	CASTER BRAKE CAP
4	2	724-112W	WLDT, CASTER YOKE
5	4	D-2008-02	BEARING, SPD, SF-16-32
6	2	H-3268	CASTER BRAKE, ADJUSTER STUD
7	4	D-4021-4	TAPER ROLLER BEARING
8	4	D-4021-5	GREASE SEAL
9	4	D-4021-6	SPACER
10	2	D-4187	TIRE & WHEEL ASSEMBLY 5 BOLT 26X12.00-12, FLAT BLACK (for 60" DECK)
-	2	D-4189	TIRE ONLY, 26X12.00-12 (for D-4187)
10	2	D-4024	TIRE & WHEEL ASSEMBLY 5 BOLT 26X14.00-12, FLAT BLACK (for 72" DECK)
-	2	D-4004	TIRE ONLY, 26X14.00-12 (for D-4024)
11	2	D-4055	TIRE ASSEMBLY, FLAT BLACK, SMOOTH, 15X6.00
12	10	F-1499	LUG NUT, 1/2-20, YZ
13	2	D-4217	CASTER BRAKE, O-RING
14	2	F-2152	NUT, 1/2-13 NYLOC, FLANGED
15	2	F-2194	HHCS, 3/4-10 X 9-1/2", YZ, GR5
16	2	F-2195	NUT, FLANGE NYLOC, YZ

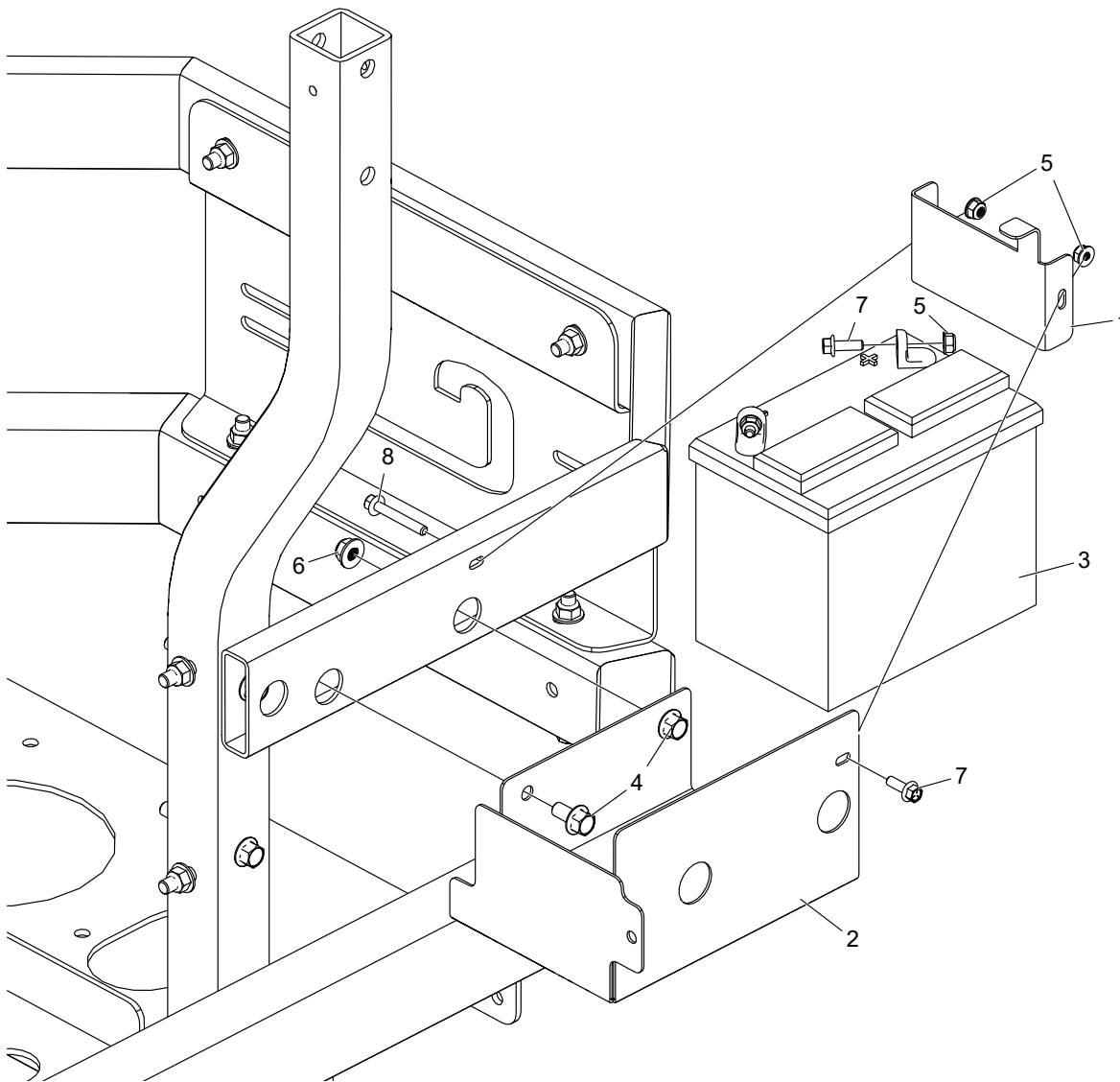

Item #	Qty	Part #	Description
1	1	724-147P	BACK PLATE, BATTERY BOX
2	1	724-148P	BATTERY BOX
3	1	----	12 VOLT BATTERY YSP 40, 350 CCA
4	2	F-2124	FHCS, 3/8-16 X 3/4", YZ, GR5
5	4	F-2132	NUT, 1/4-20 NYLOC, FLANGED, YZ
6	2	F-2151	NUT, 3/8-16 NYLOC, FLANGED, YZ
7	3	F-2162	FHCS, 1/4-20 X 3/4", YZ, GR5
8	1	F-2216	FHCS, 1/4-20 X 1-3/4", YZ, GR5

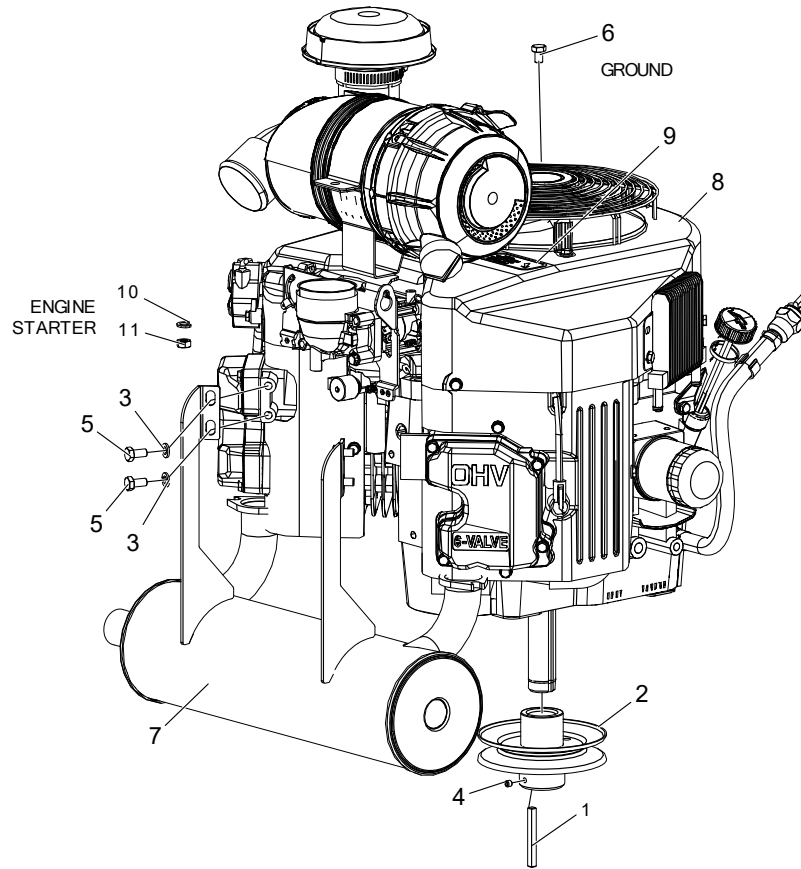

KAWASAKI

31 HP - FX921V
35 HP - FX1000V

(USE THROTTLE CABLE H-3164 & CHOKE CABLE H-3166)

Item #	Qty	Part #	Description
1	1	724-154P	KEY STOCK, 1/4 X 1/4 X 2-1/2
2	1	D-4002	MOTOR PULLEY, 5.00" DIA, W/ 1-1/8" SHAFT
3	4	F-1019-02	LOCKWASHER
4	1	F-1228	SET SCREW, SOCKET, 1/4-20 X 1/4", W/ NYLOC
5	4	F-1834	HHCS, M8 X 16MM, YZ, GR.8.8
6	1	F-2243	HHCS, M8-1.25 X 12, YZ, GR8
7	1	H-3069	MUFFLER, 5", KAWASAKI, FX100V
8	1	M-5428	ENGINE, KAWASAKI, 31 HP, FX921V
-	1	M-5429	ENGINE, KAWASAKI, 35 HP, FX1000V
9	1	P-10077-11	DECAL, "PERIODIACALLY CLEAN"
10	1	F-2258	WASHER, LOCK, M8, SS
11	1	F-2257	NUT, M8-1.25, SS

(LOOKING AT BOTTOM)

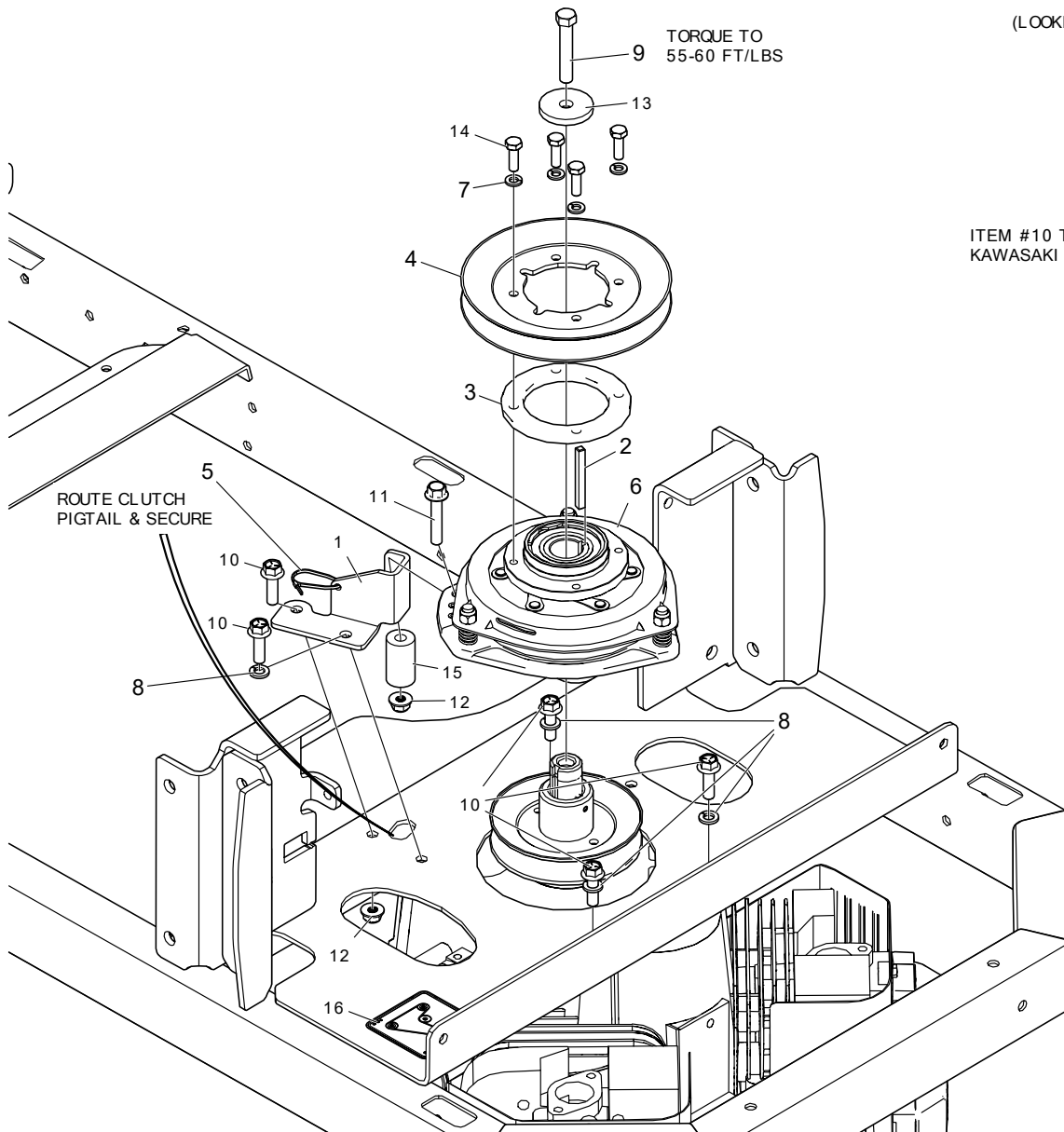

Item #	Qty	Part #	Description
1	1	724-110P	BRACKET, CLUTCH STOP (OGURA)
2	1	724-154P	KEY STOCK, 1/4 X 1/4 X 2-1/2
3	1	730-022P	SPACER, PULLEY HUB (OGURA)
4	1	D-4060	CLUTCH PULLEY, 6.75" DIA, BOLT-ON (OGURA)
5	1	E-5842	WIRE TIE
6	1	E-6710	CLUTCH, BRAKE 250 FT-LBS, 1-1/8" SHAFT
7	4	F-1019-02	LOCKWASHER
8	4	F-1019-03	LOCKWASHER, HVY, 3/8, YZ
9	1	F-2113	HHCS, 7/16-20 X 2-1/2", YZ, GR8
10	5	F-2125	FHCS, 3/8-16 X 1-1/4", YZ, GR5
11	1	F-2218	FHCS, 3/8-16 X 2-1/4", YZ, GR5
12	2	F-2151	NUT, 3/8-16 NYLOC, FLANGED, YZ
13	1	720-124P	WASHER, OGURA CLUTCH, 0.471 ID X 1.875 OD X 0.25THK
14	4	F-2299	HHCS, M8-1.25 X 25MM, GR8.8, ZINC PLATED
15	1	H-3148	BUMPER, URETHANE
16	1	P-12918	DECAL, HYDRO BELT ROUTING

E-6711 | WIRE HARNESS

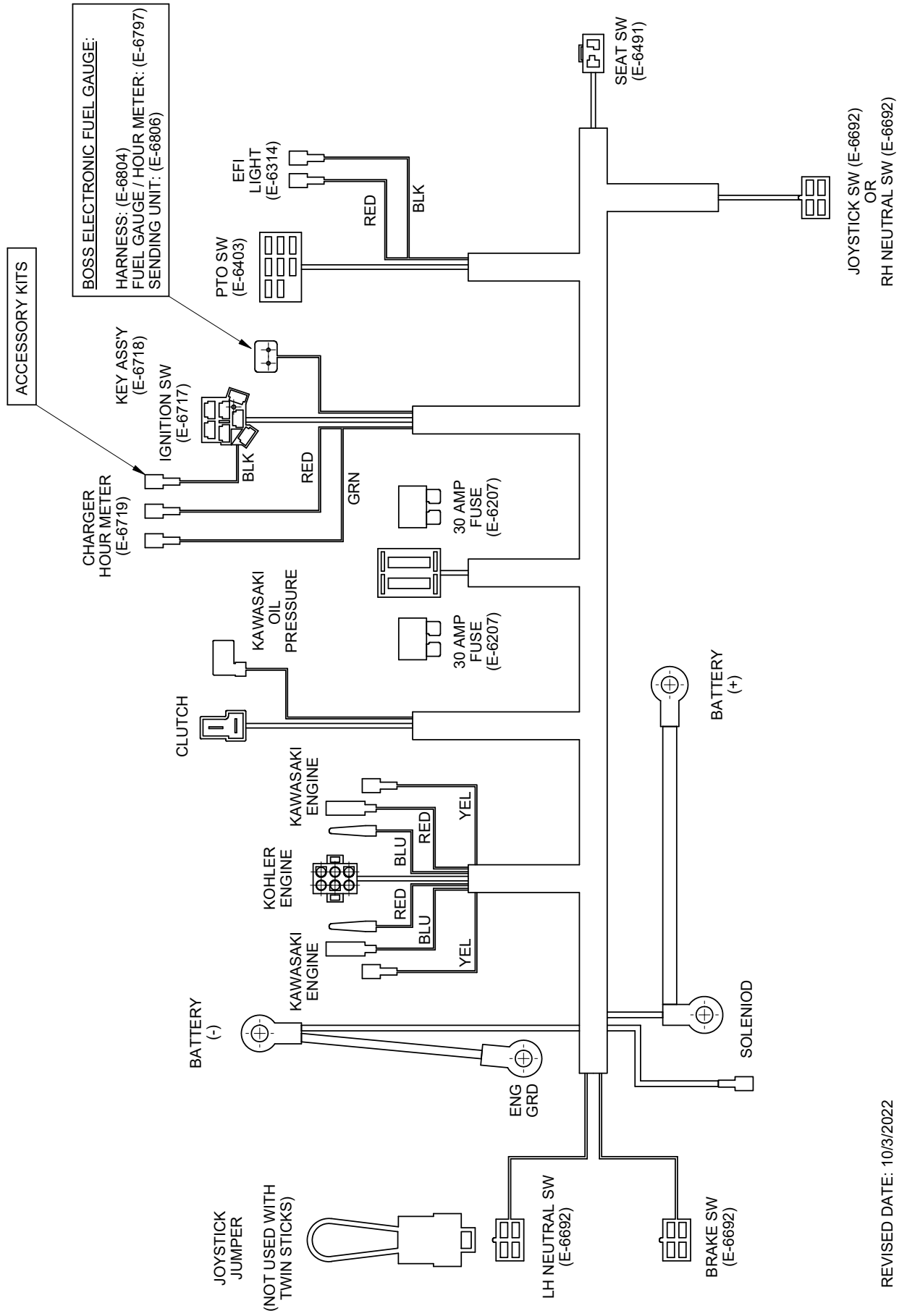

REVISED DATE: 10/3/2022

WIRING SCHEMATIC

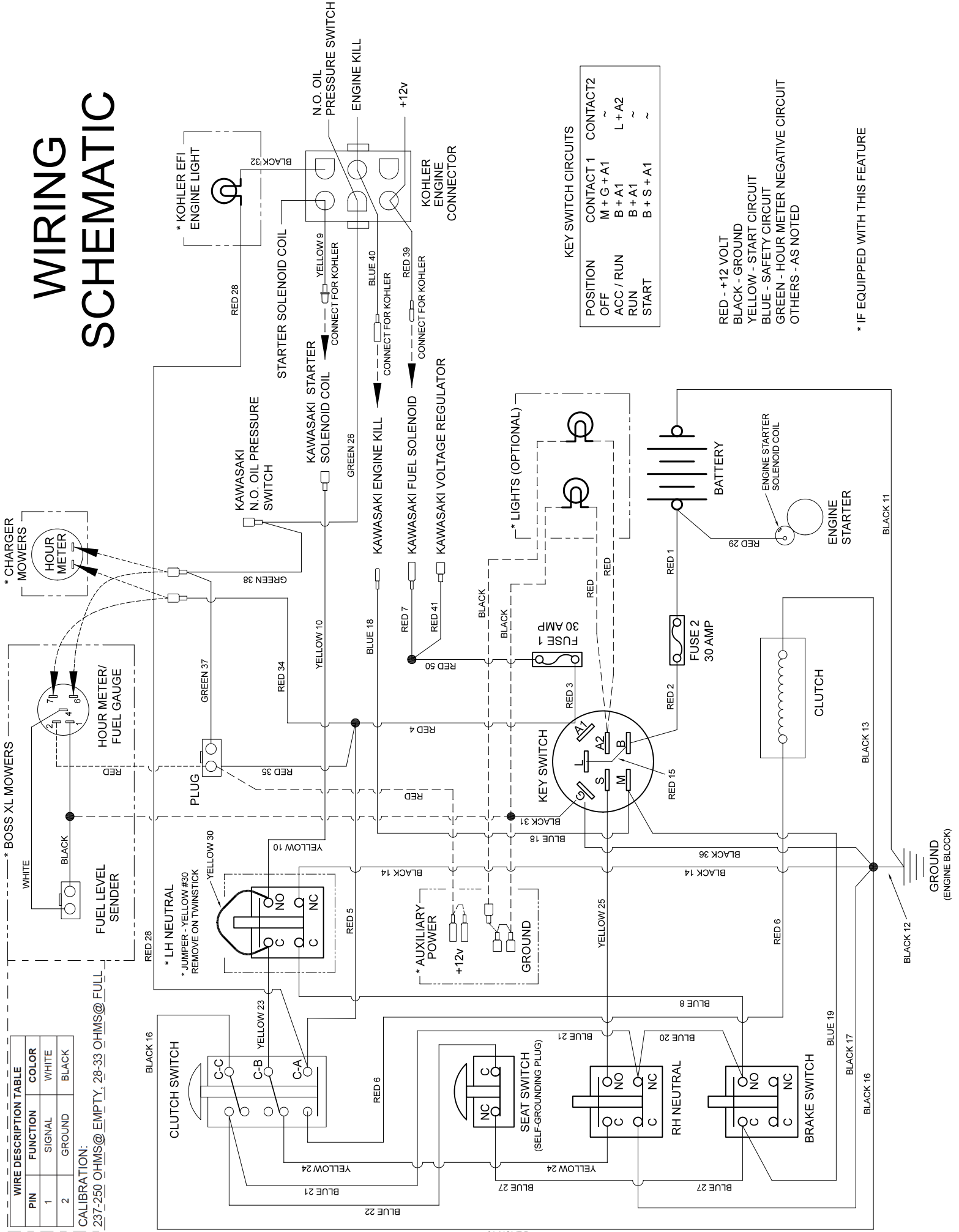

WIRE DESCRIPTION TABLE

PIN	FUNCTION	COLOR
1	SIGNAL	WHITE
2	GROUND	BLACK

CALIBRATION:
237-250 OHMS@EMPTY, 28-33 OHMS@FULL

KEY SWITCH CIRCUITS

POSITION	CONTACT 1	CONTACT 2
OFF	M + G + A1	~
ACC / RUN	B + A1	L + A2
RUN	B + A1	~
START	B + S + A1	~

- RED - +12 VOLT
- BLACK - GROUND
- YELLOW - START CIRCUIT
- BLUE - SAFETY CIRCUIT
- GREEN - HOUR METER NEGATIVE CIRCUIT
- OTHERS - AS NOTED

* IF EQUIPPED WITH THIS FEATURE

E-6781 | EFI WIRE HARNESS

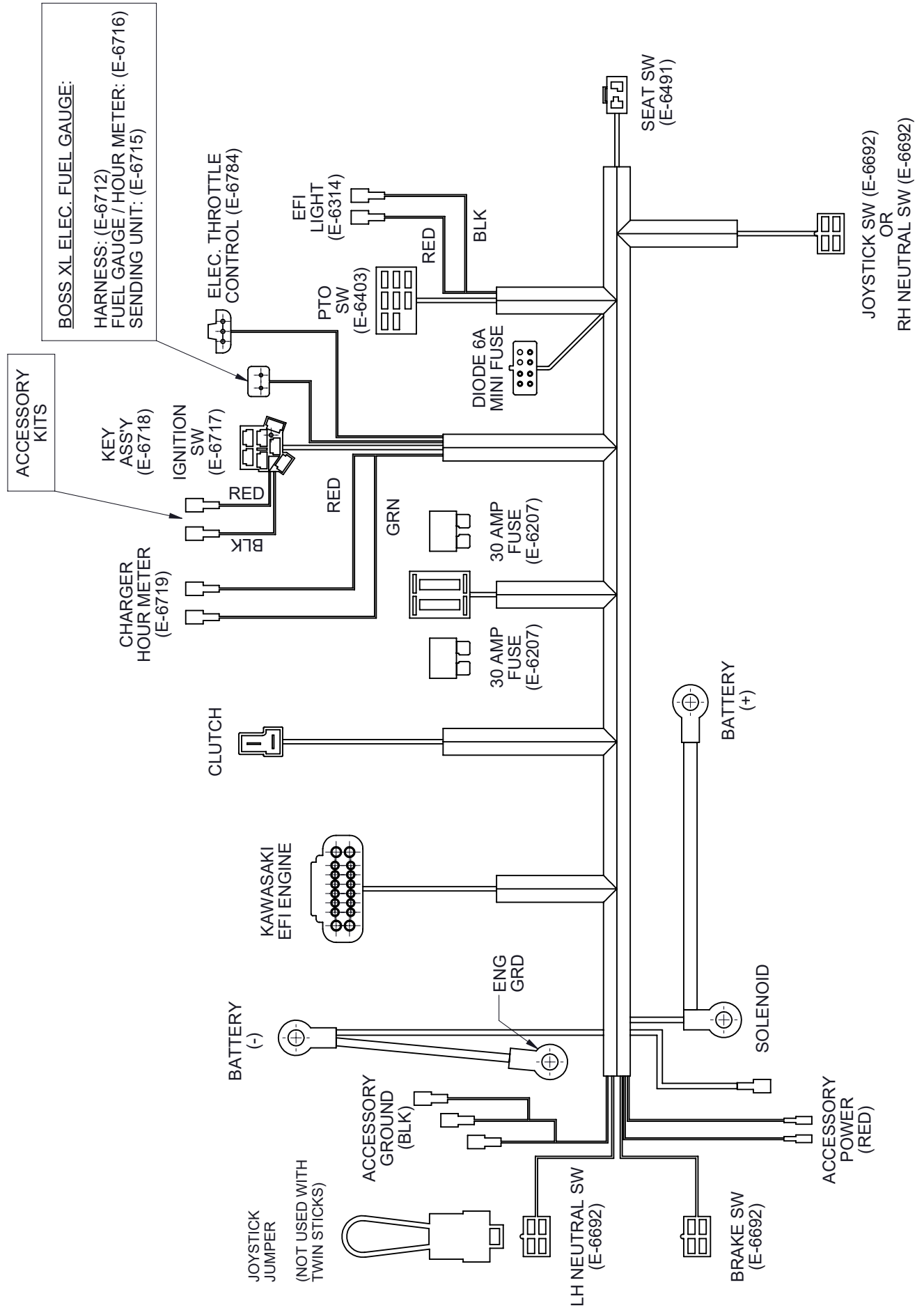

WIRING SCHEMATIC

KAWASAKI E.F.I.

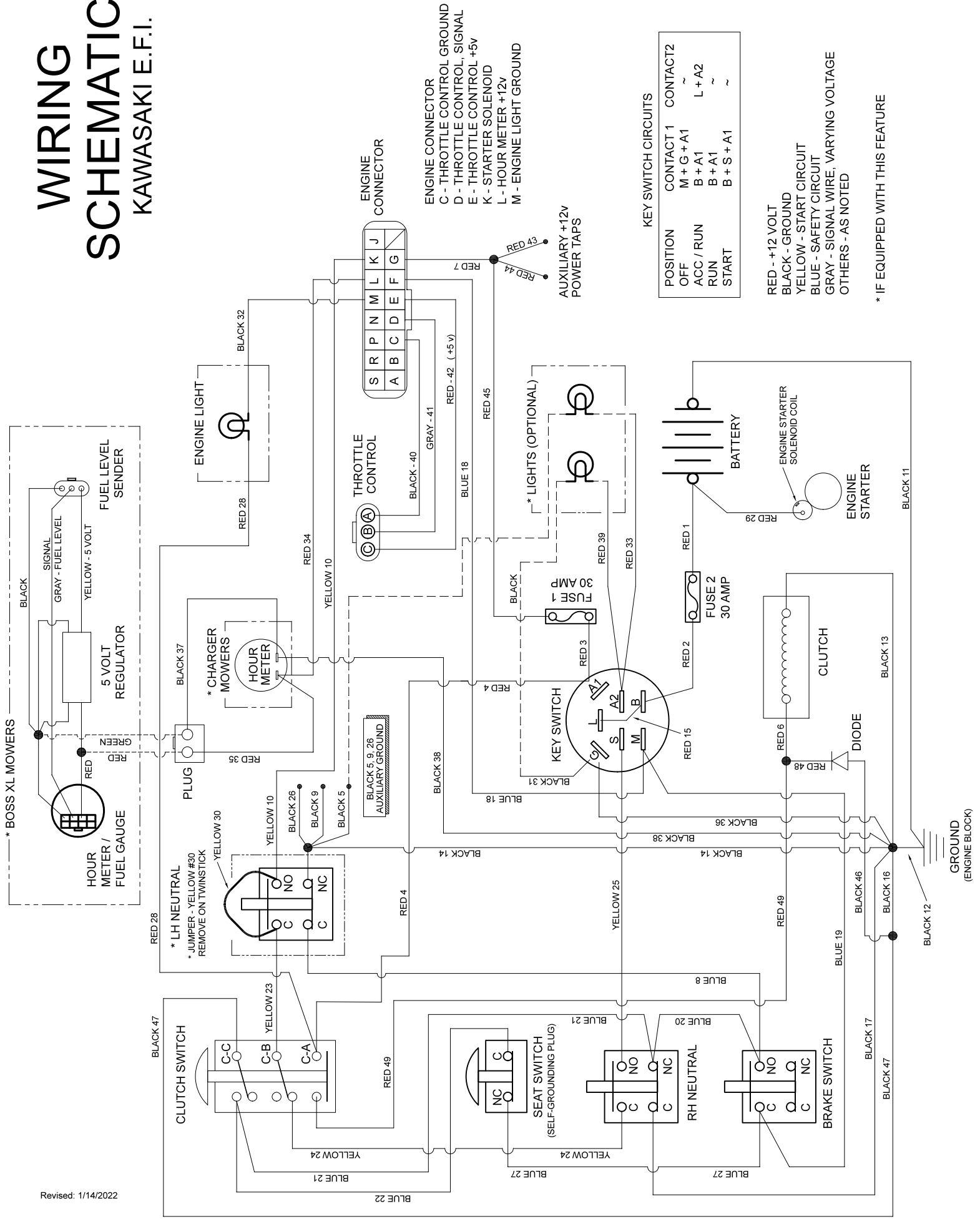

KEY SWITCH CIRCUITS

POSITION	CONTACT 1	CONTACT 2
OFF	M + G + A1	~
ACC / RUN	B + A1	L + A2
RUN	B + A1	~
START	B + S + A1	~

- RED - +12 VOLT
- BLACK - GROUND
- YELLOW - START CIRCUIT
- BLUE - SAFETY CIRCUIT
- GRAY - SIGNAL WIRE; VARYING VOLTAGE
- OTHERS - AS NOTED

* IF EQUIPPED WITH THIS FEATURE

SPECIFICATIONS

BOSS XL - Joystick Steering

MODEL	3160KAJ-9015 / 9015W	3560KAJ-9015 / 9015W	3572KAJ-9015 / 9015W
Engine	31 H.P. Kawasaki FX921V (999cc)	35 H.P. Kawasaki FX1000V (999cc)	
Hydrostatic Transmission	Hydro-Gear ZT-5400		
Steering Control	Single Joystick		
Fuel Capacity	10.25 Gallons		
Tires, Rear	26 x12-12	26 x14-12	
Tires, Front	15x6-6		
Turning Radius	Zero-Turn		
Ground Speed			
Forward	12-1/2 MPH (infinitely variable)		
Reverse	7-1/2 MPH (infinitely variable)		
Length	84-1/2"		86"
Height	48" (Folded R.O.P.S.) 75" (Top of R.O.P.S.)		49" (Folded R.O.P.S.) 76" (Top of R.O.P.S.)
Width, Tractor (outside rear tires)	57-1/2"		59-1/2"
Width, Deck (with deck chute up)	61"		73"
(with deck chute down)	73"		85"
Cutting Width	60"		72"
Blade Length (3 per deck)	21"		25"
Cutting Height	1.5" to 5" (1/4" increments)		
Weight (approx.)	1330#	1330#	1416#
Standard Features	Hour Meter, Cup Holder, Storage Tray, Electric Start, Electric Fuel Gauge, Trailer Hitch Receiver, ContourDTS Deck Suspension, Auto Detach Stand-Up Deck, R.O.P.S. (Roll Over Protection System), Suspension Seat w/ 3" Adjustable Travel, Vibration Isolators, Adjustable Seat Back Recline and Adjustable Lumbar Support		

BOSS XL - Twinstick Steering

MODEL	3560KAT-9015 / 9015W	3572KAT-9015 / 9015W
Engine	35 H.P. Kawasaki FX1000V (999cc)	
Hydrostatic Transmission	Hydro-Gear ZT-5400	
Steering Control	Twinstick	
Fuel Capacity	10.25 Gallons	
Tires, Rear	26 x12-12	26 x14-12
Tires, Front	15x6-6	
Turning Radius	Zero-Turn	
Ground Speed		
Forward	12-1/2 MPH (infinitely variable)	
Reverse	7-1/2 MPH (infinitely variable)	
Length	84-1/2"	86"
Height	48" (Folded R.O.P.S.) 75" (Top of R.O.P.S.)	49" (Folded R.O.P.S.) 76" (Top of R.O.P.S.)
Width, Tractor (outside rear tires)	57-1/2"	59-1/2"
Width, Deck (with deck chute up)	61"	73"
(with deck chute down)	73"	85"
Cutting Width	60"	72"
Blade Length (3 per deck)	21"	25"
Cutting Height	1.5" to 5" (1/4" increments)	
Weight (approx.)	1338#	1424#
Standard Features	Hour Meter, Cup Holder, Storage Tray, Electric Start, Electric Fuel Gauge, Trailer Hitch Receiver, ContourDTS Deck Suspension, Auto Detach Stand-Up Deck, R.O.P.S. (Roll Over Protection System), Suspension Seat w/ 3" Adjustable Travel, Vibration Isolators, Adjustable Seat Back Recline and Adjustable Lumbar Support	

Specifications subject to change without prior notice



PRODUCT MANUAL

BOSS^{XL} 9015 / 9015W

Country Clipper Division

Shivvers Manufacturing, Inc.

613 W. English St.

Corydon, IA 50060-0467

Ph. 641-872-2544

Fax. 641-872-1593

P-13730 (Rev B)